

Since 1968

COMMAX
SmartHome & Security

User Manual

Guardhouse Interphone CDS-481L



www.commax.com

COMMAX Co.,Ltd.



- Thank you for purchasing COMMAX products.
- Please carefully read this User's Guide (in particular, precautions for safety) before using a product and follow instructions to use a product exactly.
- The company is not responsible for any safety accidents caused by abnormal operation of the product.

Introduction

WARNING

To prevent fire or shock hazard, do not expose the unit to rain or moisture.



CAUTION
RISK OF ELECTRIC SHOCK
DO NOT OPEN



CAUTION : TO REDUCE THE RISK OF ELECTRIC SHOCK, DO NOT REMOVE COVER (OR BACK). NO USER-SERVICEABLE PARTS INSIDE. REFER SERVICING TO QUALIFIED SERVICE PERSONNEL.



This symbol is intended to alert the user to the presence of uninsulated “**dangerous voltage**” within the product’s enclosure that may be of sufficient magnitude to constitute a risk of electric shock to persons.



This symbol is intended to alert the user to the presence of important operating and maintenance (servicing) instructions in the literature accompanying the unit.

INFORMATION

This equipment generates and uses radio frequency energy and if not installed and used properly; that is, in strict accordance with the manufacturer’s instructions, may cause interference to radio and television reception. It has been type tested and found to comply with the limitations for a Class B computing device in accordance with the specifications in Subpart J of Part 15 of the FCC Rules, which are designed to provide reasonable protection against such interference in a residential installation. However, there is no guarantee that interference will not occur in a particular installation. If this equipment does cause interference to radio or television reception, which can be determined by turning the equipment off and on, the user is encouraged to try to correct the interference by one or more of the following measures:

- *Reorient or relocate the receiving antenna.*
- *Increase the separation between the equipment and receiver.*
- *Connect the equipment to an outlet of a circuit different from that to which the receiver is connected.*
- *Consult the dealer or on experienced radio/TV technician for help.*

TO PREVENT ELECTRIC SHOCK, DO NOT USE THIS POLARIZED AC PLUG WITH AN EXTENSION CORD, RECEPTACLE OR OTHER OUTLET, UNLESS THE BLADES CAN BE FULLY INSERTED TO PREVENT BLADE EXPOSURE.

Important Safety Instructions

1. **Read Instructions** - All the safety and operating instructions should be read before the product is operated.

2. **Retain Instructions** - The safety and operating instructions should be retained for future reference.

3. **Heed Warnings** - All warnings on the product and in the operating instructions should be adhered to.

4. **Follow Instructions** - All operating and use instructions should be followed.

5. **Cleaning** - Unplug this product from the wall outlet before cleaning. Do not use liquid cleaners or aerosol. Use a damp cloth for cleaning.

6. **Attachments** - Do not use attachments not recommended by the product manufacturer, as they may cause hazards.

7. **Water and Moisture** - Do not use this product near water - for example, near a bath tub, wash bowl, kitchen sink, laundry tub, in a wet basement, near a swimming pool, and the like.

8. **Accessories** - Do not place this product on an unstable cart, stand, tripod bracket, or table. The product may fall, causing serious injury to a child or adult, and serious damage to the product. Use only with a cart, stand, tripod, bracket, or table recommended by the manufacturer, or sold with the product. Any mounting of the product should follow the manufacturer's instructions, and should use a mounting accessory recommended by the manufacturer.

9. A product and cart combination should be moved with care. Quickstops, excessive force, and uneven surfaces

may cause the product and cart combination to overturn.



10. **Ventilation** - Slots and openings in the cabinet are provided for ventilation and to ensure reliable operation of the product.

They protect it from overheating, and these openings must not be blocked or covered. The openings should never be blocked by placing the product on a bed, sofa, rug, or other similar surface. This product should not be placed in a built-in installation such as a bookcase or rack unless proper ventilation is provided, or the manufacturer's instructions have been adhered to.

11. **Power Sources** - This product should be operated only from the type of power source indicated on the marking label. If you are not sure of the type of power supply in your home, consult your product dealer or local power company. For products intended for operation from battery power or other sources, refer to the operating instructions.

12. **Grounding or Polarization** - This product may be equipped with a polarized alternating-current line plug (a plug having one blade wider than the other). This plug will fit into the power outlet only one way. This is a safety feature. If you are unable to insert the plug fully into the outlet, try reversing the plug. If the plug still cannot be inserted, contact your electrician to replace your obsolete outlet. Do not defeat the safety purpose of the polarized plug.

Important Safety Instructions

13. **Power-Card Protection** - Power-supply cords should be routed so that they are not likely to be walked on or pinched by items placed upon or against them paying particular attention to cords at plugs, convenience receptacles, and the point where they exit from the product.
14. **Protective Attachment Plug** - The product is equipped with an attachment plug having overload protection. This is a safety feature. See instruction Manual for replacement of, or resetting the protective device. If replacement of the plug is required, be sure the service technician has uses a replacement plug specified by the manufacturer that has the same overload protection as the original plug.
15. **Outdoor Antenna Grounding** - If an outside antenna or cable system is connected to the product, be sure the antenna or cable system is grounded so as to provide some protection against voltage surges and built-up static charges. Article 810 of the National Electrical Code, ANSI/NFPA 70, provides information with regard to proper grounding of the mast and supporting structure, grounding of the lead-in wire to an antenna discharge unit, size of grounding conductors, location of antenna-discharge unit, connection to grounding electrodes, and requirements for the grounding electrode (Refer to the figure on page 5).
16. **Lightning** - For added protection of this product during a lightning storm, or when it is left unattended and unused for long periods of time, unplug it from the wall outlet and disconnect the antenna or cable system. This will prevent damage to the product due to lightning and power-line surges.
17. **Power Lines** - An outside antenna system should not be located in the vicinity of overhead power lines or other electric light or power circuits, or where it can fall into such power lines or circuits.
When installing on outside antenna system, extreme care should be taken to keep from touching such power lines or circuits as contact with them might be fatal.
18. **Overloading** - Do not overload wall outlets, extension cords, or integral convenience receptacles, as this can result in a risk of fire or electric shock.
19. **Object and Liquid Entry** - Never push objects of any kind into this product through openings as they may touch dangerous voltage points or short-out parts that could result in a fire or electric shock. Never spill liquid of any kind on the product.
20. **Servicing** - Do not attempt to service this product yourself as opening or removing covers may expose you to dangerous voltage or other hazards. Refer all servicing to qualified service personnel.
21. **Damage Requiring Service** - Unplug this product from the wall outlet and refer servicing to qualified service personnel under the following conditions.
 - A. When the power-supply cord or plug is damaged.
 - B. If liquid has been spilled, or objects have fallen into the product.
 - C. If the product has been exposed to rain or water.

Important Safety Instructions

D. If the product does not operate normally by following the operating instructions. Adjust only those controls that are covered by the operating instructions, as an improper adjustment of other controls may result in damage and will often require extensive work by a qualified technician to restore the product to its normal operation.

E. If the product has been dropped or damaged in any way.

F. When the product exhibits a distinct change in performance - this indicates a need or service.

22. **Replacement Parts** - When replacement parts are required, be sure the service technician has used replacement parts specified by the manufacturer or have the same characteristics as the original part. Unauthorized substitutions may result in fire, electric shock or other hazards.

23. **Safety Check** - Upon completion of any service or repairs to this product, ask the service technician to

perform safety checks to determine that the product is in proper operating condition.

24. **Wall or Ceiling Mounting** - The product should be mounted to a wall or ceiling only as recommended by the manufacturer.

25. **Heat** - The product should be situated away from heat sources such as radiators, heat resistors, or other products (including amplifiers) that produce heat.

EXAMPLE OF ANTENNA GROUNDING AS PER NATIONAL ELECTRICAL CODE

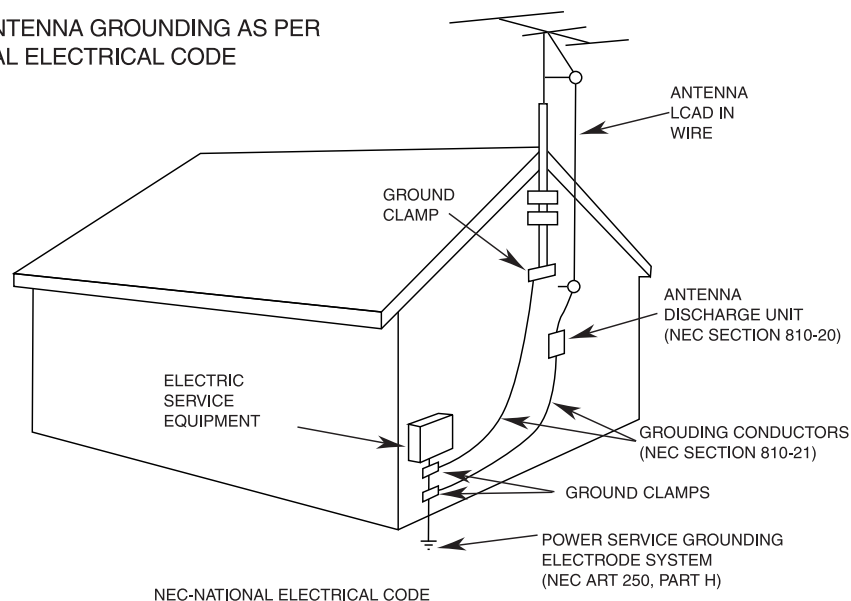

NEC-NATIONAL ELECTRICAL CODE

Table of Contents

Introduction	1
Important Safety Instructions	2
Table of Contents	5
1. Greetings.....	6
2. Before Getting Started.....	6
3. Overview	
3-1. Overview	7
3-2. Essentials.....	8
4. To Connect with Households	
4-1. Being Paged by the Household	10
4-1-1. Request from the Household to Confirm the Last Household it has Connected	
to 10	
4-2. Paging the Household from the Guardhouse (Paging another Guardhouse)	11
5. To Connect a Household with another Household.....	12
6. Selecting and Answering Missed Pages	13
7. Connecting to the Main Entrance	
7-1. To Connect to the Guardhouse from the Main Entrance	14
7-2. To Connect to the Main Entrance From the Guardhouse	15
8. Paging and Connecting to a Household using Registered Vehicle Numbers (Parking Management System).....	16
9. Announcement	17
10. Call Block	18
11. Away Mode Setting and Security Mode Extension from the Guardhouse	19
12. Emergencies within Households	22
13. Delivery	24
14. Confirming Household Conditions.....	25
15. Adjusting Time.....	30
16. Advanced Feature (Please use only after understanding its handling to the full)	
16-1. Registering Household Numbers	31
16-2 Registering Household Vehicles (Parking Management System)	
16-2-1. Registering with Known Vehicle Number	32
16-2-2. Registration by the Household through the Guardhouse.....	34
16-3. Checking Household Numbers using Vehicle Numbers	36
16-4. To Open or Close the Main Entrance	
16-4-1. To Temporarily Release the Main Entrance	36
16-4-2. To Open the Entrance for Indefinitely	38
16-4-3. To Close Main Entrances	39
17. Guardhouse Interphone Program Confirmation and Modification.....	41
[Table 1] Guardhouse Interphone Program Number and Description.....	46
18. Wiring Method	48
19. Specifications	57

1. Greetings

- Thank you for purchasing a Commax product.
- This state-of-the-art Guardhouse Interphone switchboard contains a parking management system, individual household checking features, and various other essential services in security. Please read this user manual carefully and familiarize yourself with its contents before use.
- Being a product that utilizes the common wiring method, adhering yourself to basic wiring instructions when installing will surely prove this product as a convenient one.

2. Before Getting Started

- Using 8-wire common wiring method between the Main Entrance interphone and the Guardhouse interphone, this system supports 3 communication circuits, and each communication circuit is a Balance Type that supports 2 wires.
- Using 18-wire common wiring method between the Guardhouse interphone and the Guardhouse interphone, this system supports 8 communication circuits, and each communication circuit is a Balance Type that supports 2 wires.
- Shorts or disconnection in wiring are factors of product malfunction. Please check them before wiring

※ Remarks

3. Overview

3-1. Overview

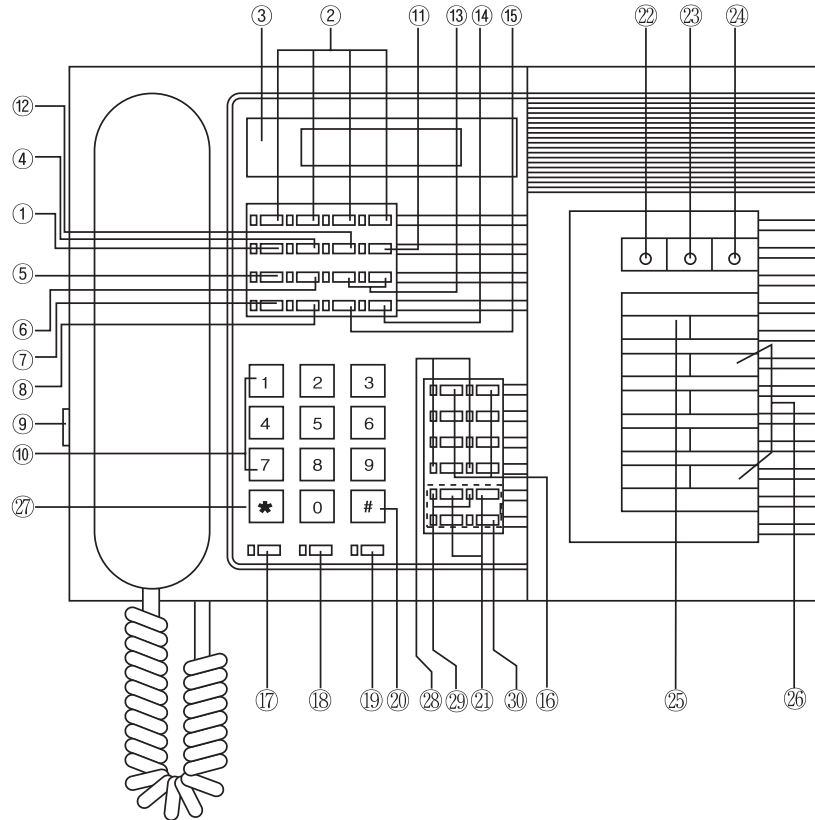

Number	Description	Number	Description
1.	Time Adjustment Button	16.	Speed Dial Buttons
2.	Household Selection Button	17.	P.A. Button
3.	LCD	18.	Call Connection Button
4.	Enter Button	19.	Speakerphone
5.	Away Button	20.	Call Button
6.	Remote Control Button	21.	Parking Management System
7.	Extension Button	22.	Emergency Lamp
8.	Redial Button	23.	Away Lamp
9.	Volume Adjustment	24.	Call Lamp
10.	Key Pad	25.	Guardhouse Indicator Section
11.	Call Block Button	26.	Household Indicator Section
12.	Confirmation Button	27.	Building Button
13.	Change Location Buttons (←, →)	28.	Outside Line Lamp
14.	Open	29.	Internal Line Lamp
15.	Emergency Page	30.	Delivery Button

3-2. Essentials

- *Household Selection Button/Lamp: Used to select one of the Households indicated on the Household Indicator Section.
- *Time Adjustment Button/Lamp: Used to adjust time.
- *Enter Button/Lamp: Used to execute the Guardhouse Interphone's programs.\
- *Confirmation Button/Lamp: Used to confirm changes made to data within the Guardhouse Interphone's programs.
- *Call Block Button/Lamp: Forwards calls to other Guardhouses or Households. (Available only when a forwarding number has been entered in Pr03)
- * Away Registration Button/Lamp: Controls the Household Videophone's Away feature from the Guardhouse.
- * Remote Control Button/Lam: Used to verify and adjust various information of the Household Videophone.
- * (← →) Button/Lamp: Used to confirm or make changes to entered data.
- * Extension Button/Lamp: Used to assign Multi Sub numbers to the Household Videophone and in various other extension processes.
- * Redial Button/Lamp: Pages the last number paged.
- * Emergency Page/Lamp: Pages to connect to a Household with an emergency.
- * Open Button/Lamp: Used to release the Main Entrance.

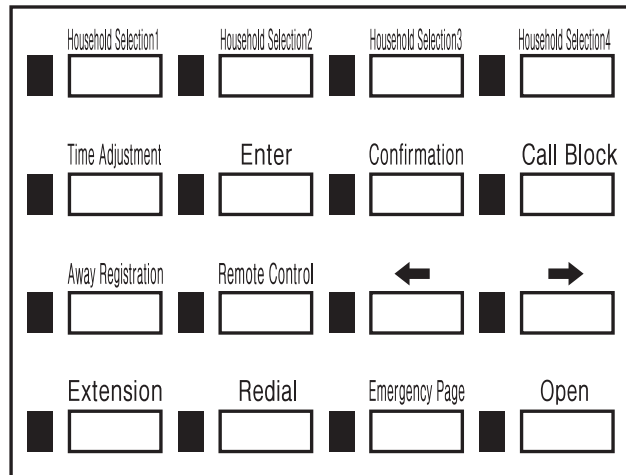

Selection Switches

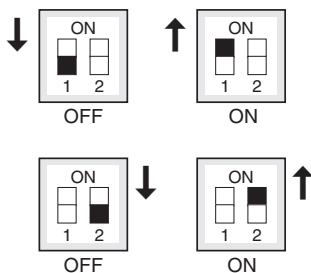

No. 1: OFF - cannot be connected to a computer.

: ON - can be connected to a computer.

: (Computer connection feature is optional)

No. 2: OFF - Household emergencies are received by all installed Guardhouse Interphones.

: ON - Household emergencies are received only by the corresponding Guardhouse.

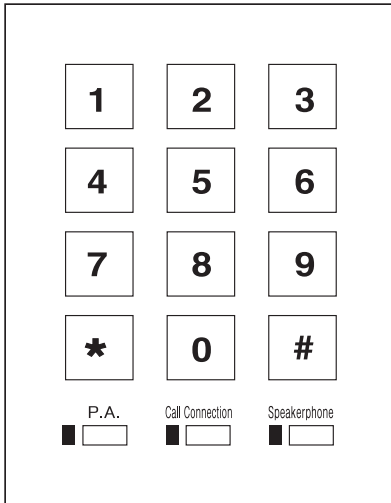

- * Key Pad: Used to enter in numbers.
- * Building Button: Used to distinguish buildings when entering Household numbers.
- * Call Button (#): Used to page after entering a Household number.\
- * P.A. Button/Lamp: Used for announcements among Guardhouses
- * Call Connect Button/Lamp: Used to connect a Household to another Household or another Guardhouse.
- * Speakerphone Button/Lamp: Activates the speakerphone.

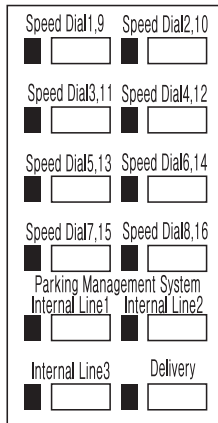

- * Speed Dial Buttons (No. 1) : Often dialed numbers
- * Line Indicators(LED) Red/Blue: Indicates the status of each outside line(1 to 8)
- * Internal Line Indicator (LED): Indicates the status of each internal line (1 to 3).
- * Confirmation Button: Used when verifying a Household using Vehicle Number.
- * Vehicle Button: Used to page a Household using Vehicle Number. (Two vehicles can be registered per household)

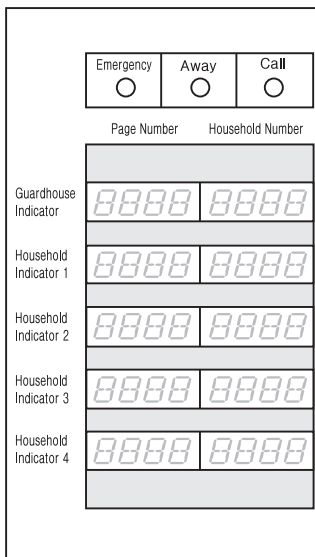

- * Emergency Indicator (Blinks when an Emergency Page has been made)
- * Away Indicator (Blinks when an Emergency Page or Call has been made from a Household in Away Mode)
- * Page Indicator (Blinks with paging and other data communication)

*The lamp will continuously blink when an error or short has been detected along the Data Line.

*The following messages are indicated on the LCD:
 Int Com Line Err : Internal Line Error
 Ext Com Line Err : Outside Line Error

- * Guardhouse Indicator Section
- * Household Indicator Section

4. To Connect with Households

4-1. Being Paged by the Household

- ① A paging signal will sound from the Guardhouse interphone when a Household has paged the Guardhouse.



Pickup the Receiver to answer.

ex) From Building 101, Unit 101.

- ② Pickup the Receiver to answer.

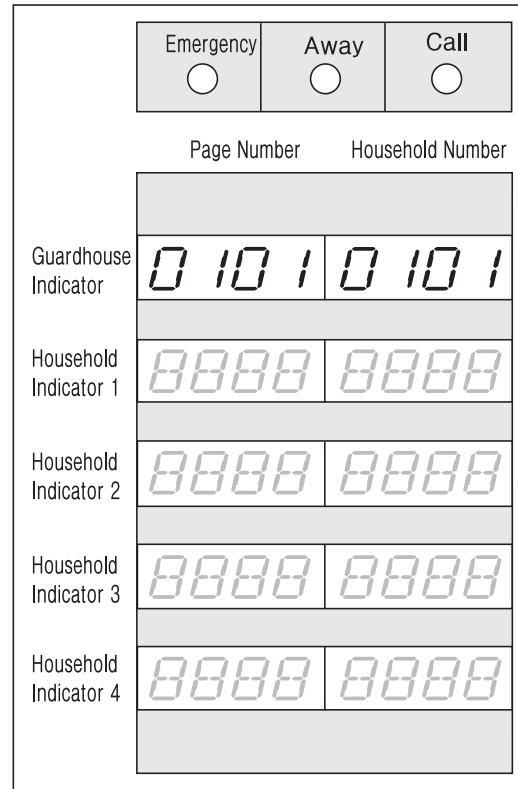

4-1-1. Request from the Household to Confirm the Last Household it has Connected to

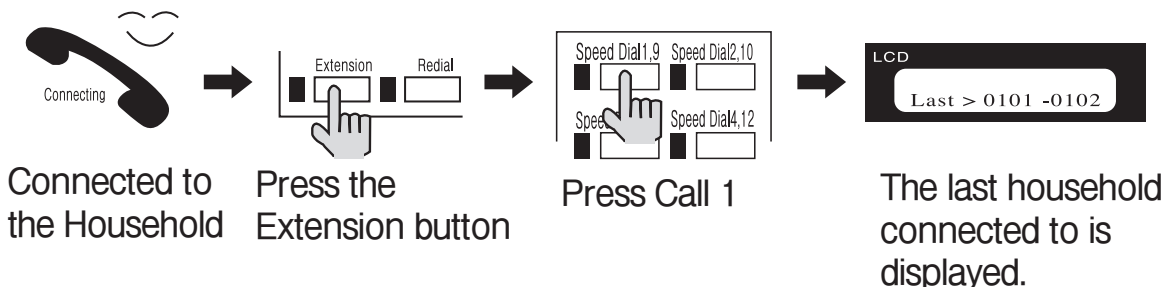

- ① While staying connected with the Household,
- ② Press the Extension button.
- ③ Press Outside Line 1 button. (Indicated while the Outside Line 1 button has been pressed)
- ④ The last Household connected to the Household on line is displayed on the LCD. Inform the Household of its last connection.

4-2. Paging the Household from the Guardhouse (Paging another Guardhouse)

- ① Pickup the receiver and enter the Building Number of the Household to connect to using the Key Pad. (To page another Guardhouse, enter in 9999)

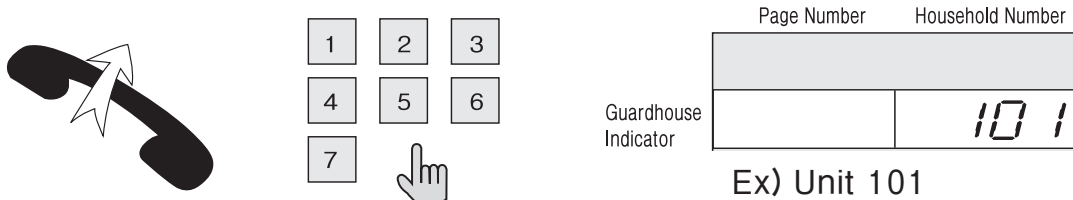

- ② Press the Building button (*). (The number indicated on the LCD and the Guardhouse Indicator Section moves to the Building location)



- ③ Enter the Household Number using the Key Pad. (To page another Guardhouse, enter the Guardhouse Interphone's Serial Number)



- ④ Press the Call button. (Ringing tone will sound)



- ⑤ Await a reply.



- ⑥ If a busy signal is heard, hang-up and page again after a few minutes.

5. To Connect a Household with another Household

※ (Warning) Guardhouse calls cannot be forwarded.

- ① When a request to connect to another household has been made while connected to the Household,
- ② Press the Call Connection button. (The lamp will light up)

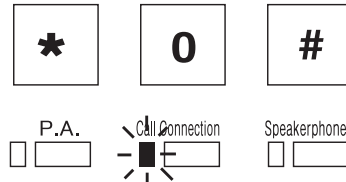

- ③ Use the Key Pad to enter in the Household Building Number to connect to and press the Building button.

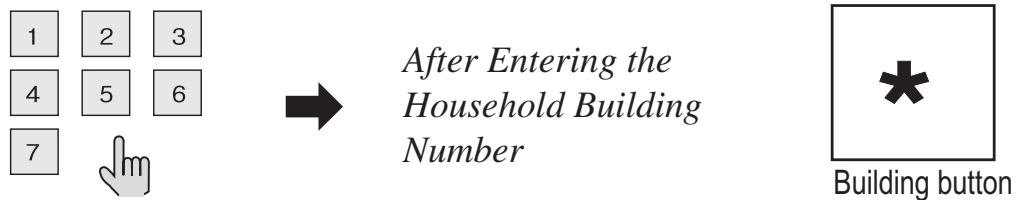

- ④ Use the Key Pad to enter in the Household Number to connect to and press the Page button. (Ringing tone, lit up Call Connect lamp, and 'Exchange OK' indicated on the LCD)

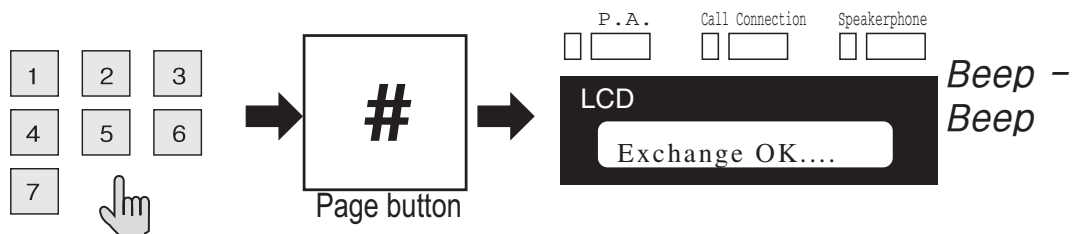

If wrong Building Number or Household Number has been entered, use the Correction (←) button to make changes.

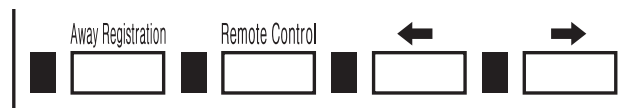

- ⑤ Hang-up.



6. Selecting and Answering Missed Pages

- ① When a Household page has been made while the Guardhouse Interphone's line was busy, the Household Number where the page originated from and the Household Selection Button/Lamp light up on the Household Indicator Section.

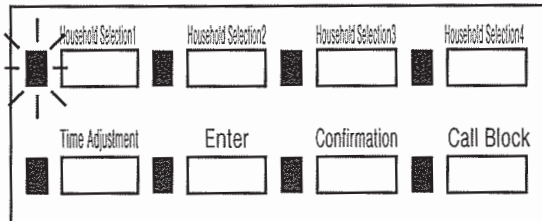

“When the Guardhouse is on a call with Unit 101 from Building 101”

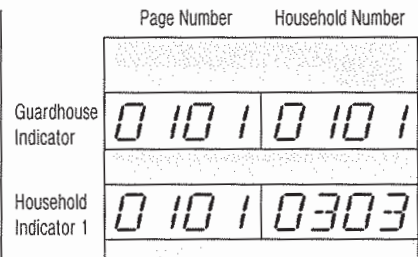

Ex) Being paged by Unit 303 from Building 101

- ② Press the Household Selection button after ending the initial call to connect with the second Household.

“After Ending the Call Household Select 1”

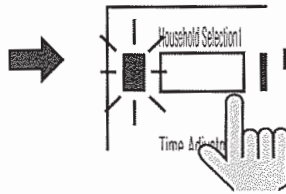

“Connecting to the Following Household.
Ex) Being paged by Unit 303 from Building 101”

<Note>

If the Household indicated on the Household Indicator Section is not selected within 30 seconds, that Household will no longer be indicated on the top portion of that section and be replaced by the next Household in line.

7. Connecting to the Main Entrance

7-1. To Connect to the Guardhouse from the Main Entrance

- ① A paging signal will sound when the Guardhouse has been paged from the Main Entrance.
(Main Entrance Number indicated on the LCD and the Guardhouse Indicator Section)

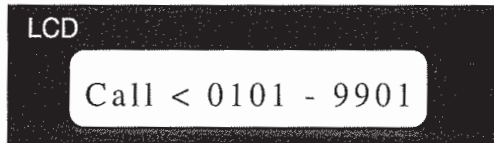

A Paging Signal will Sound

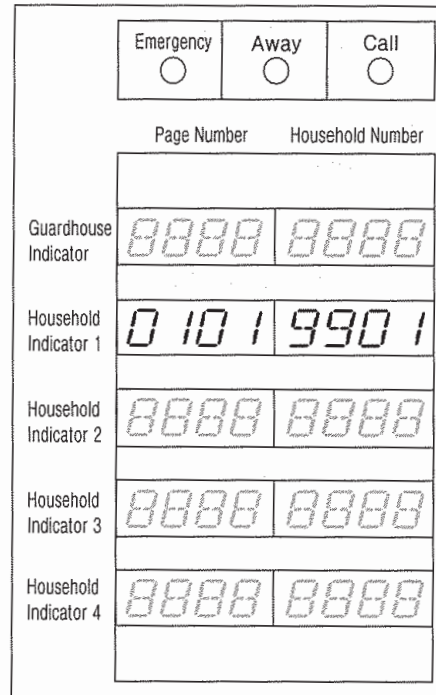

- ② Pickup the receiver to answer.



- ③ Pressing the Door Release button while connected to an entrance will open it.

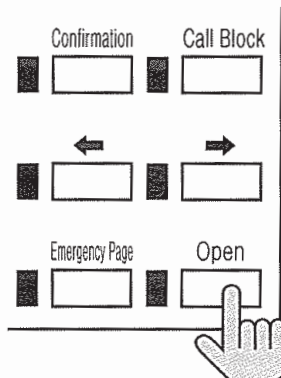

The Main Entrance will Open



↳ OPEN : OPEN the Door

2. To Connect to the Main Entrance From the Guardhouse

- ① Pick up the receiver and press the number of the entrance to connect to.

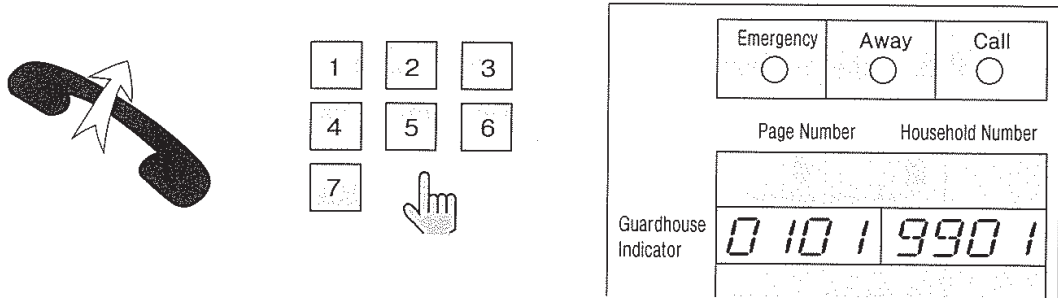

Ex) To connect to the first Main Entrance of Building 101.

- ② Press the Page button.

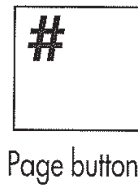

A Paging Signal will Sound

- ③ Await for a reply.

Connecting to the Main Entrance

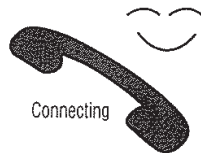

- ④ Pressing the Door Release button while connected to an entrance will open it.

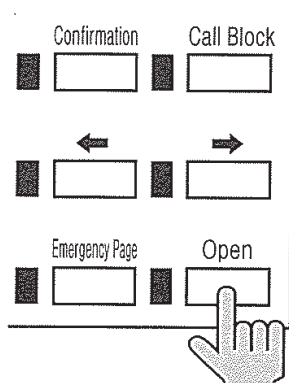

The Main Entrance will Open

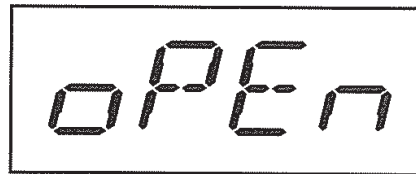

OPEN : OPEN the Door

8. Paging and Connecting to a Household using Registered Vehicle Numbers (Parking Management System)

* This feature is only available when Vehicle Numbers have been registered to each Household.
(Refer to the registration method in 16-2)

- ① Pickup the receiver and enter the number of the vehicle registered in the Parking Management System. ('car> - ' will be displayed on the LCD)

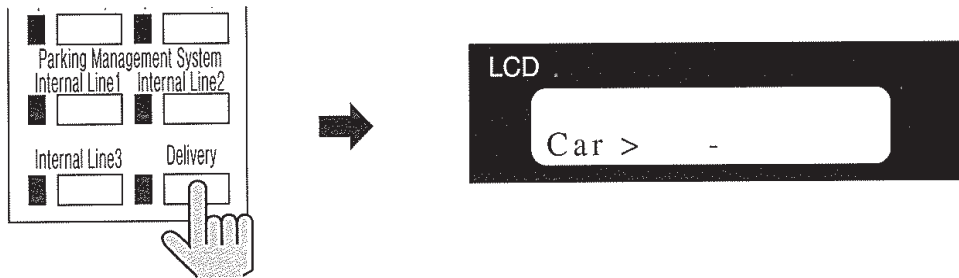

- ② Use the Key Pad to enter in the vehicle's region number and press the Building button. Use the Key Pad to enter in the vehicle's 4-digit number and press the Page button.

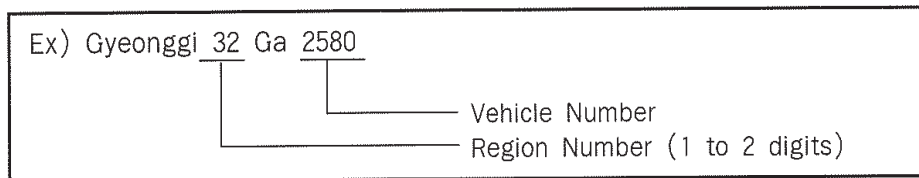
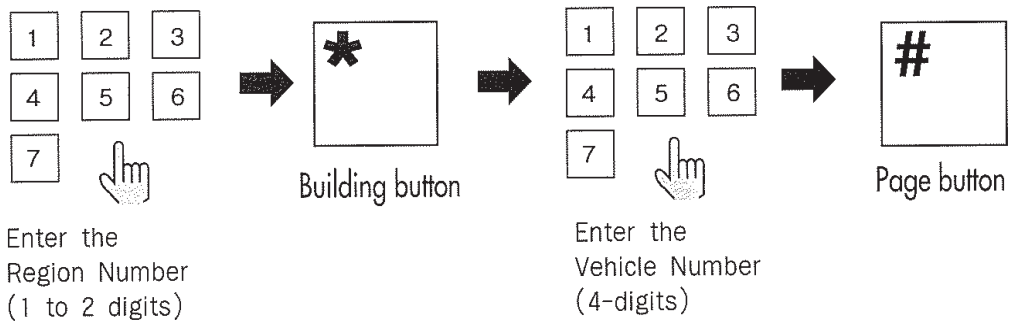

* To page a household using the above vehicle number: Pickup the receiver - Press the Vehicle Button - Enter 32 - Press the Building button -- Enter 2580 - Press the Page button ? Wait for a reply

- ③ Await a reply.



9. Announcement

- ① Pickup the receiver and enter the group number to announce to using the Key Pad.

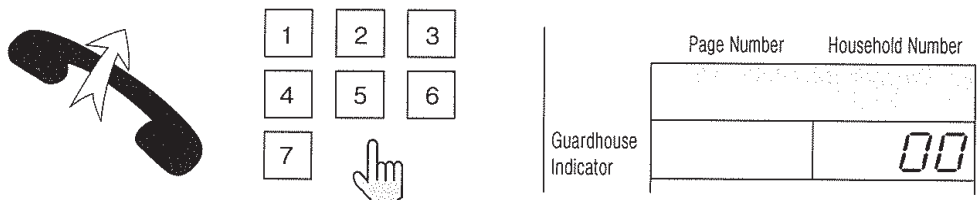

- ② Press the P.A. button.

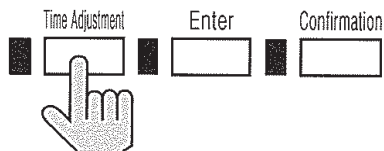

Announcement Indication
Signal will Sound

- ③ After the announcement indication sounds, make the announcement.



Start the Announcement

<Note>

(As for Announcement Groups, please refer to data recorded in Pr22 of the Guardhouse interphone)

00 : All ⇒ Announcement is heard through all installed Guardhouse interphones.

01 : Group 1 only ⇒ Announcement is heard through Guardhouse interphones designated under Group 1 only.

※ If the Guardhouse interphone is on a call, the announcement will not be made through that interphone.

※ On the LCD of the Guardhouse interphone where the announcement is made from, numbers of announcement receiving interphones are displayed.

10. Call Block

* Used when the Guardhouse is left unattended. (This feature is only available when data has been entered into Pr03 from "Guardhouse Interphone Program Confirmation and Modification")

* This feature is disabled when the Guardhouse interphone has been turned off, then on.

- ① Press the Call Block button.
- ② The Call Block lamp will light up.

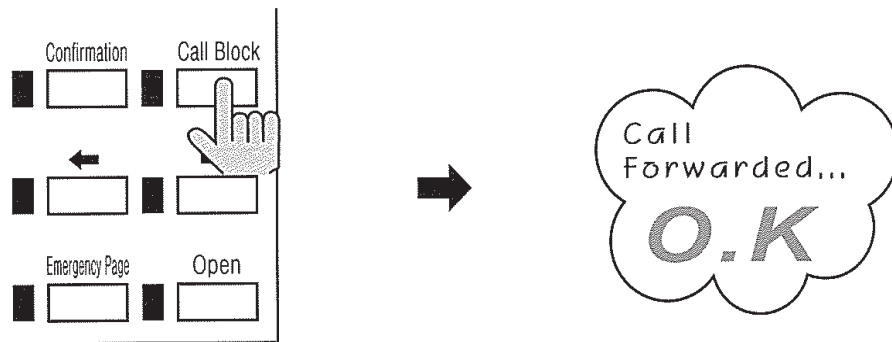

"All calls are forwarded to the designated Guardhouse."

To disable, press the Call Block button once more.

(Pressing the Speakerphone button or picking up the receiver will also disable)

Method 1: Press the Call Block button again

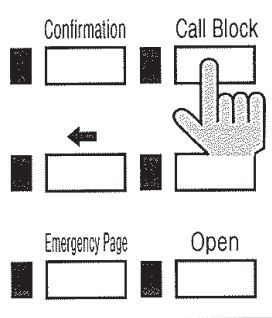

Method 2: Pickup the receiver



Method 3: Press the Speakerphone button

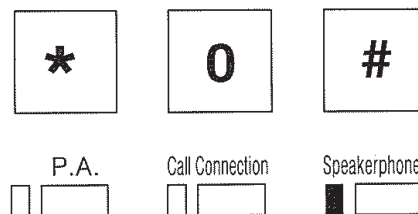

<Note>

To configure it so that this feature continues to be active when the Guardhouse interphone has been turned off then on, enter 8888 for Pr04 from "Guardhouse Interphone Program Confirmation and Modification." To disable, enter 0000.

11. Away Mode Setting and Security Mode Extension from the Guardhouse

- * When the Away Status has been registered at the Guardhouse for a Household, that Household will go into Security Mode right away. (If a door installed with security sensors within the Household is opened, Security Mode will not be activated)
- * Security Guard Activation Delay is not cancellation of the Away Mode but is a feature that delays the activation time of Household Security Guard.

11-1. Setting the Household in Away Mode from the Guardhouse

- ① Press the Away button.
(Away LED lights up)
(Speakerphone LED lights up)

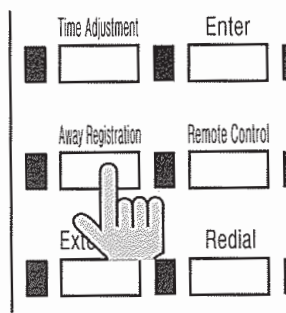

- ② Enter the Building Number of the Household to have set in Away Mode then the Building button, and the Household Number then the Call button (#).

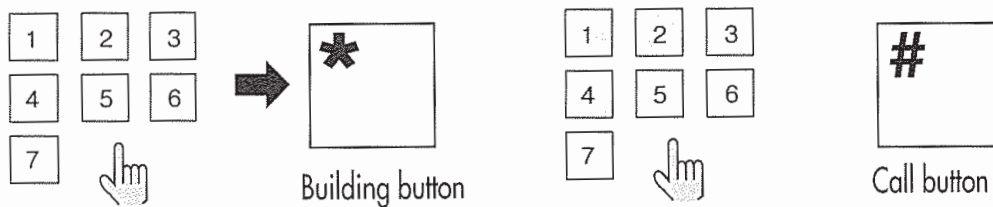

- ③ The following message will appear on the LCD:



- ④ If a door installed with security sensors within the Household is opened, an error message will display on the LCD as shown below:



⑤ Press the Speakerphone button to end.

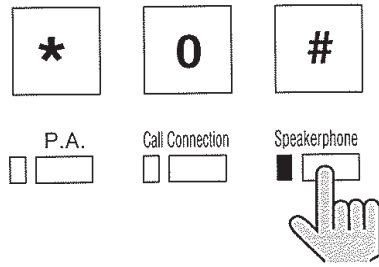

11-2. Verifying Away Status of the Household from the Guardhouse

① Pickup the receiver or press the Speakerphone button.

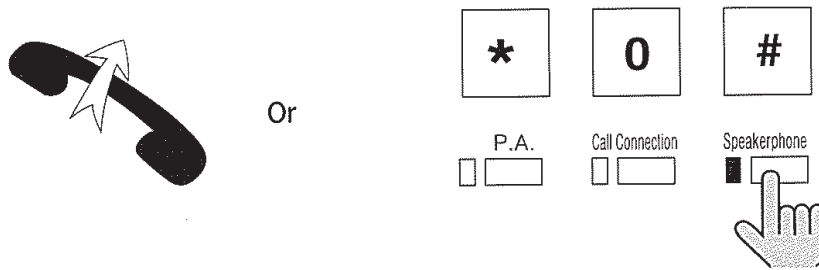

② Enter the Building and Household Number and press the Call button.

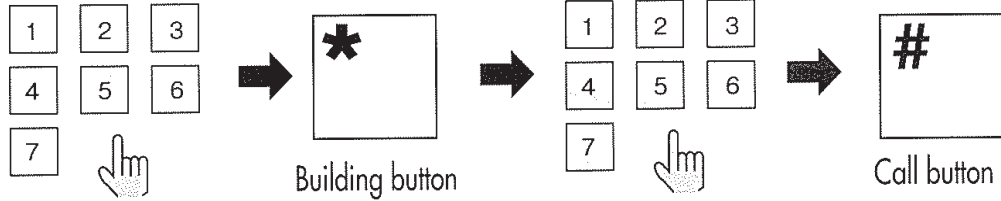

③ If the residents are away, oUt (OUT) will be displayed.

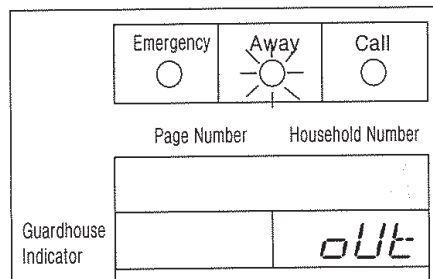

Blinking LED

“Currently Away”

④ Put down the receiver to end.

After Confirming the Away Status



11-3. Security Guard Delay from the Guardhouse

- ① Press the Remote Control button.

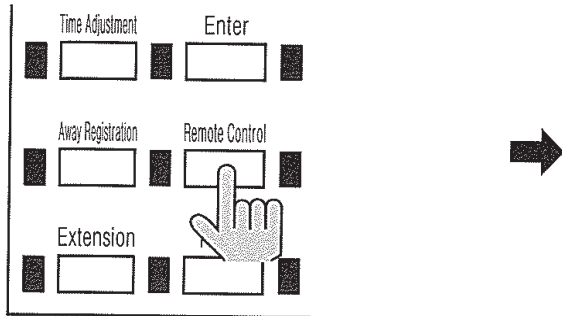

- ② Enter the Building Number and the Household Number and press the Away button.

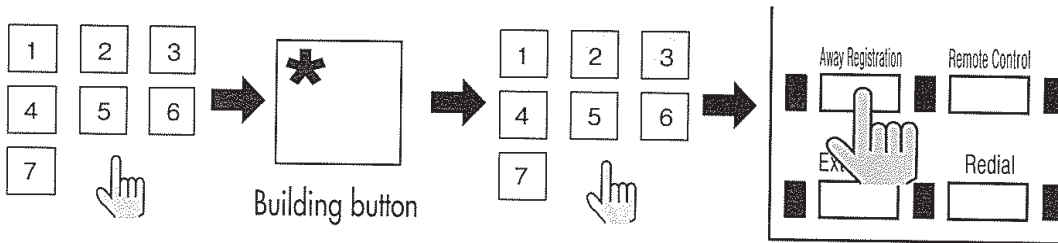

- ③ When the Security Guard has been delayed, the following will appear on the LCD:

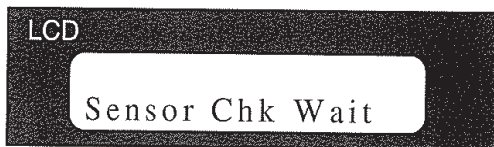

- ④ Press the Speakerphone button to end.

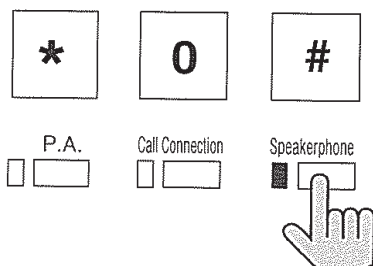

* Household Security Guard Activation has been delayed

* For 10 minutes from the moment of ordering Guard Activation Delay, no alarm will sound even if the Household door is opened.

12. Emergencies within Households

12-1. Sensor Caused Emergencies

(Maximum 4 emergency indications can be made simultaneously. (Maximum 16 emergency notifications))

- ① Emergency notifications are transmitted to all connected Guardhouse Interphones.
(Designated by the Selection Switch No.2 on page 6)
- ② Siren will sound and Building and Household numbers will blink on the Household Indicator Section.

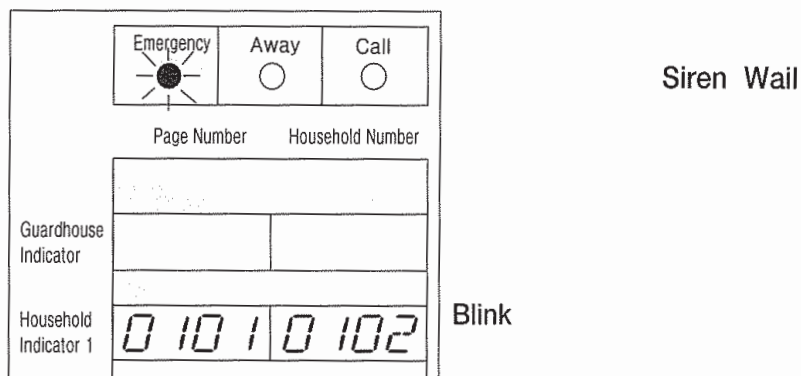

- ③ This state will continue until an emergency page has been made to that Household from the Guardhouse. If the Household 1 is in Away Mode, the Away lamp (LED) will also blink.

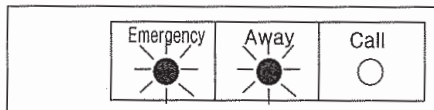

12-2. Emergency Page

- ① Pickup the receiver or press the Speakerphone button, then press the Emergency Page button. (The highest-ranking Household will be paged when the Emergency Page button is pressed)

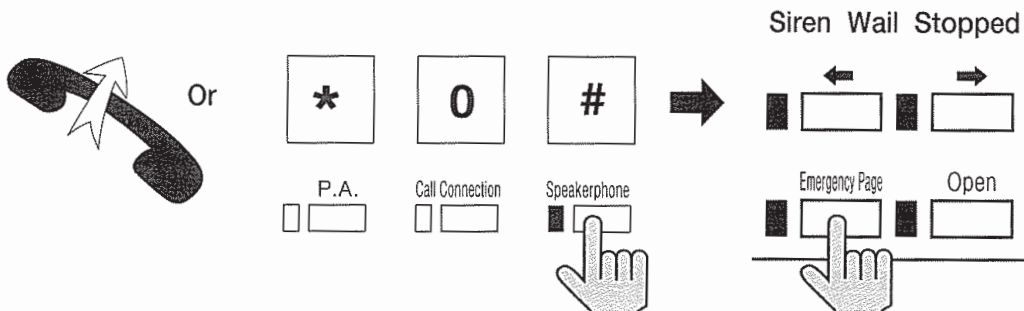

- ② Household with the emergency is indicated on the Guardhouse Indicator Section.

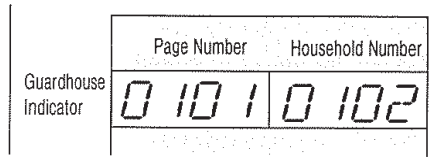

- ③ When the blinking stops, the page is made.
* Alarm corresponding to the emergency is sounded.

Electronic Gun: Emergency
Fire Truck: Fire
Ambulance: Gas Leak
Police Siren: Burglar Intrusion

If the Household cannot sound alarms, each of the following situations is indicated:

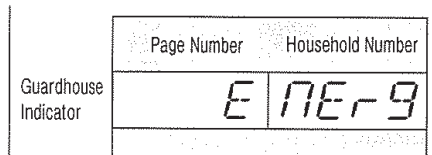

In state of emergency - Emergency

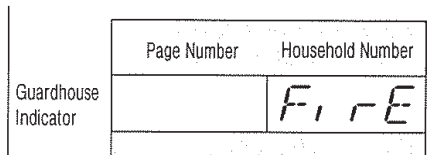

Fire detection - Fire

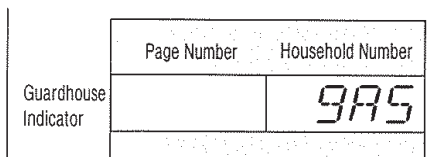

Gas leak - Gas

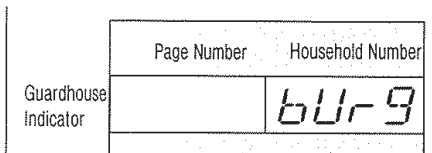

Burglar intrusion - Burglar

- ④ Place the receiver down to end.



13. Delivery

* When the Household pages the Guardhouse, the page is routed to the Guardhouse that has made the Delivery Page.

① Press the Speakerphone button.

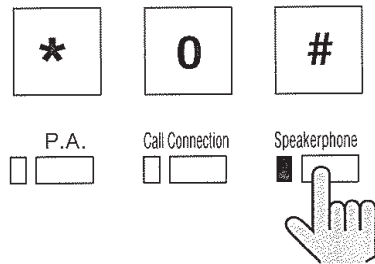

② Enter the Building Number, press the Building button, and enter the Household Number.

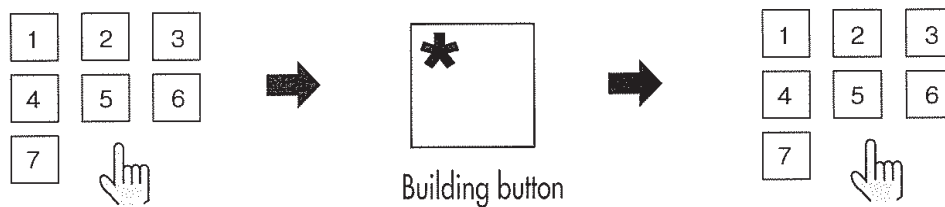

③ Press the Delivery button.

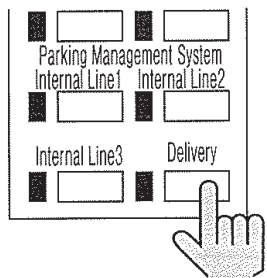

* Power lamp on the Household Videophone blinks

④ Press the Speakerphone button to end.
The Household will call.

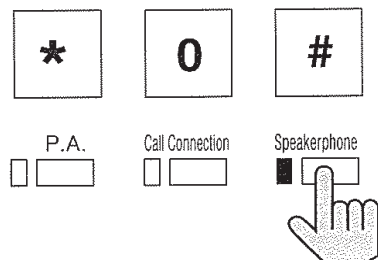

14. Confirming Household Conditions

14-1. To Confirm Household Conditions (1 Household)

① Press the Remote Control button. ("Rmot> - " will display on the LCD)

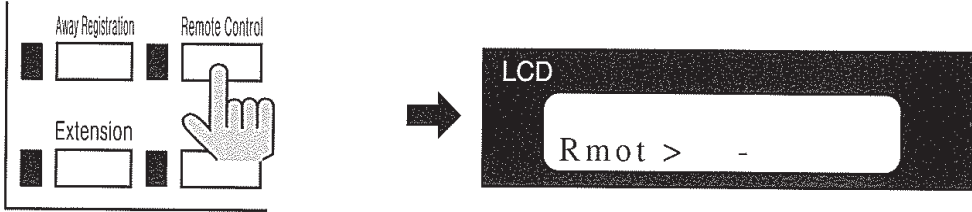

② Enter the Building Number, press the Building button, enter the Household Number, and press the Extension button.

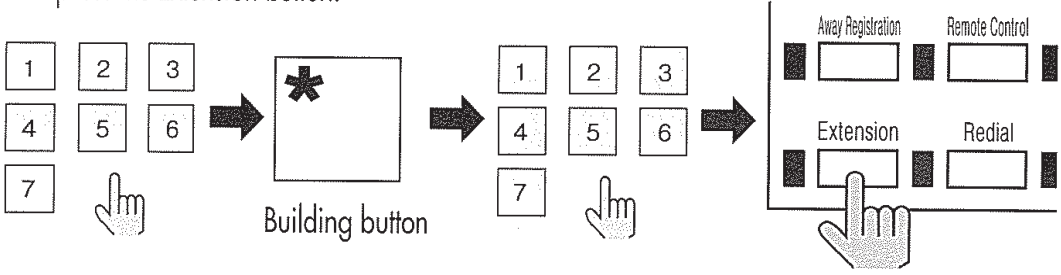

* If the Page button is pressed instead of the Extension button, the Master is selected.

③ Enter the Multi Sub Number and press the Page button.
SUB Numbers range from 0 to 9.

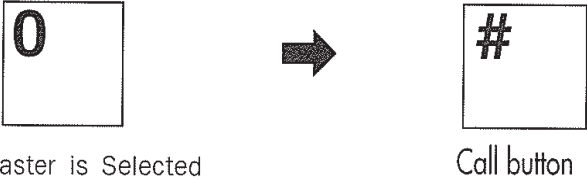

④ The following are indicated on 7-Segment

	Page Number	Household Number
Guardhouse Indicator	n	oNRL
Household Indicator 1	101	102
Household Indicator 2	000	1000
Household Indicator 3	000	0000

- A. Household's Current Status
- B. Household Number
- C. Household Sensor Status
- D. Household's Burglary Status & Away Status

A. Household's Current Status

Indicates the Household's status, indicated by the following:

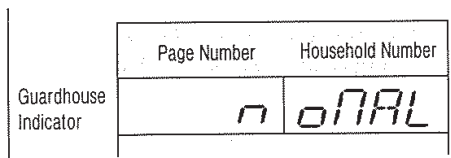

Normal: Normal Status

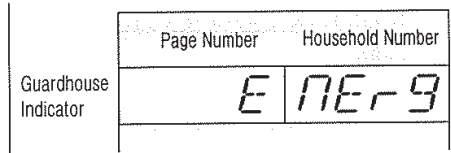

Emergency: Emergency Situation

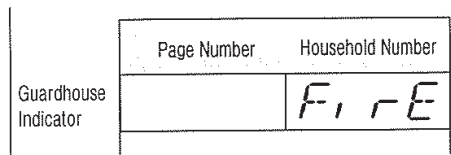

Fire: Activation of Fire Sensors within the Household

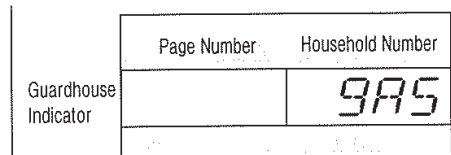

Gas: Activation of Gas Detectors within the Household

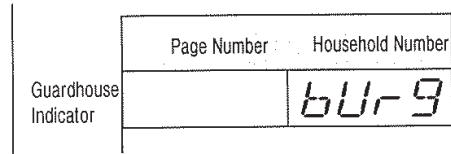

Burglar: Detection of Intrusion

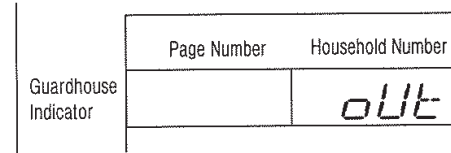

Out Door House: Residences Away

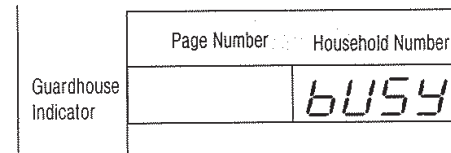

Busy: The Household is currently on a call.

B. Household Number

Indicates the Household currently under review.

Press the Household Select button 1 to view other Households.



C. Household Sensor Status

Indicates the status of each sensor in the Household.

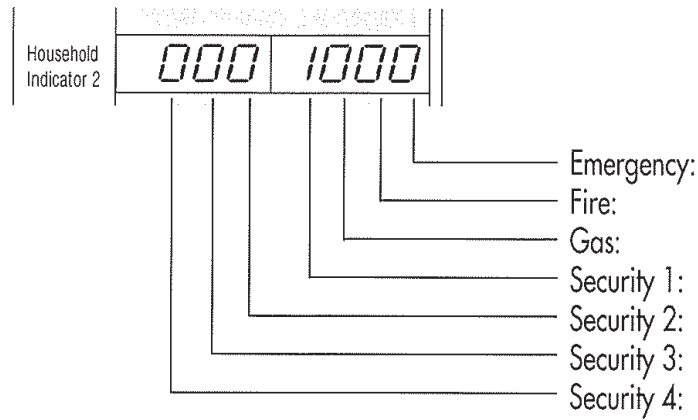

Emergency: Emergency switch within the Household activated (1)

Fire: Fire sensor within the Household activated (1)

Gas: Gas detectors within the Household activated (1)

Security 1: Security 1 activated (1)

Security 2: Security 2 activated (1)

Security 3: Security 3 activated (1)

Security 4: Security 4 activated (1)

D. Household's Burglary Status & Away Status



Indicated when residences are away.

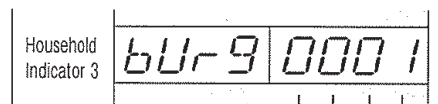

Indicates active burglary sensors within the Household.

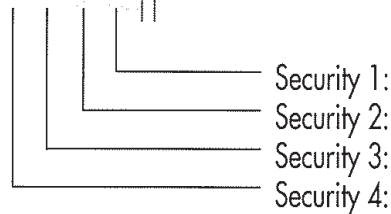

14-2. To Confirm Household Conditions (Automated, to confirm 1 building)

- * This feature checks all interphones installed within 1 building.
- * If more than one interphone is connected to a Household, only its Master is checked.

① Press the Remote Control button.

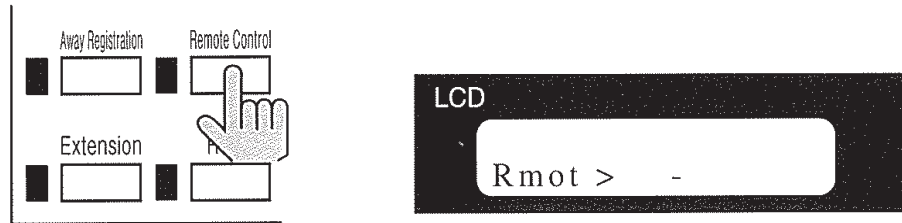

② Enter the Building Number, press the Building button, then enter in the Household Number on the lowest floor of that building.

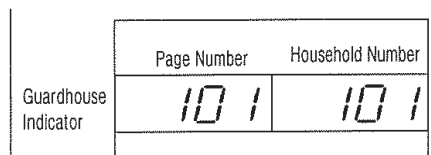
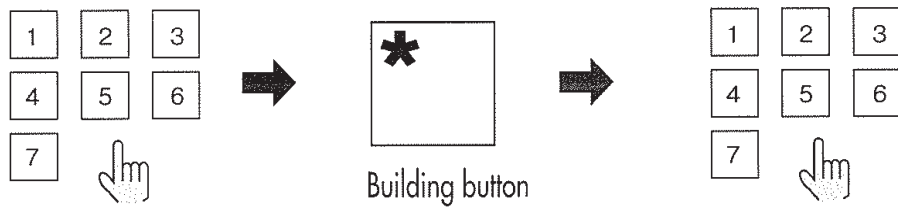

Ex) When Unit 101, Building 101 has been entered.

③ Press the Extension button.

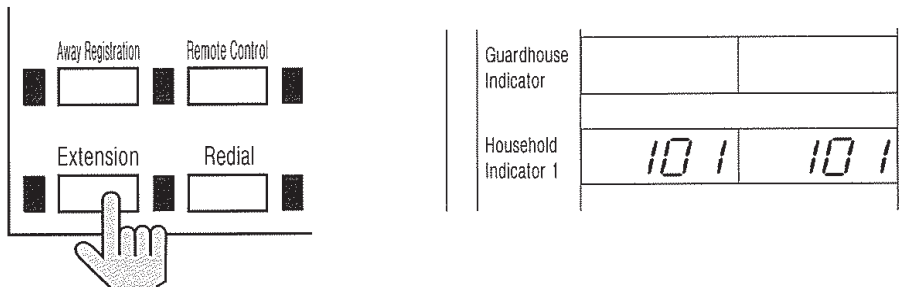

④ Press the Confirmation button.

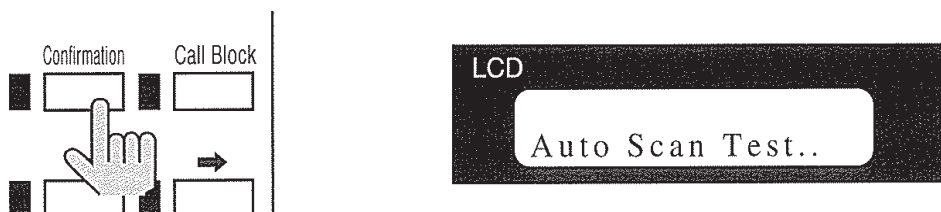

⑤ Enter the Household Number on the highest floor. (Do not enter the Building Number)

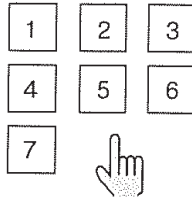

	Page Number	Household Number
Guardhouse Indicator		2202

⑥ Press the Call button.
Households are automatically checked.

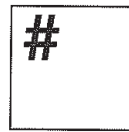

Call button

	Page Number	Household Number
Guardhouse Indicator	Error	
Household Indicator 1	101	101
Household Indicator 2		2202

Error' will be indicated on the Guardhouse Indicator Section if an error is detected, and its details are indicated on the Household Indicator Section. Automatic inspection is paused.

⑦ Press the Call button.
Press the Call button again to skip to the next Household.

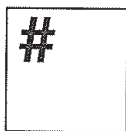

Call button

15. Adjusting Time

* Do not pickup the receiver when adjusting time.

- ① Press the Time Adjustment button.

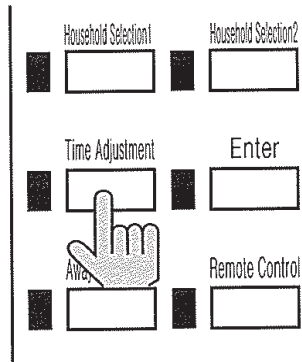

- ② Enter in the following order: YY(Year)-MM(Month)-DD(Day)-HH(Hour)-MM(Minute)-W(Day of the Week)

Days of the Week - 0(Sun), 1(Mon), 2(Tue), 3(Wed), 4(Thu), 5(Fri), 6(Sat)

(Enter hours based on the 24-hour clock)

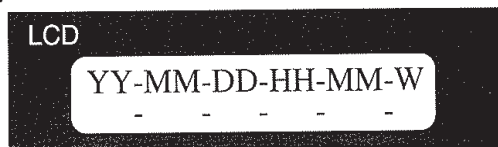

Ex) To Set as Monday, October 11th, 1999, 9:30AM.

Time Adjustment Button → 99 10 11 09 30 1 → Enter Button
 Year Month Day Time Minute Day of the Week
 (Enter hours based on the 24-hour clock)

- ③ Press the Enter button.

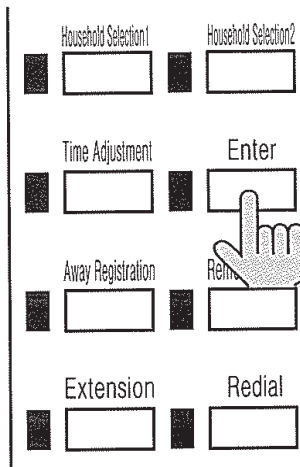

16. Advanced Feature (Please use only after understanding its handling to the full)

16-1. Registering Household Numbers

This feature is only available when the Household has paged the Guardhouse and is still connected to the Guardhouse. (Does not function when the Household is paged by the Guardhouse)

- ① Pickup the receiver and press the Guard button from the Household.

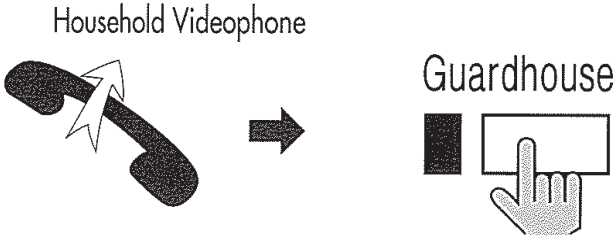

- ② Pickup the receiver and press the Remote Control button from the Guardhouse.

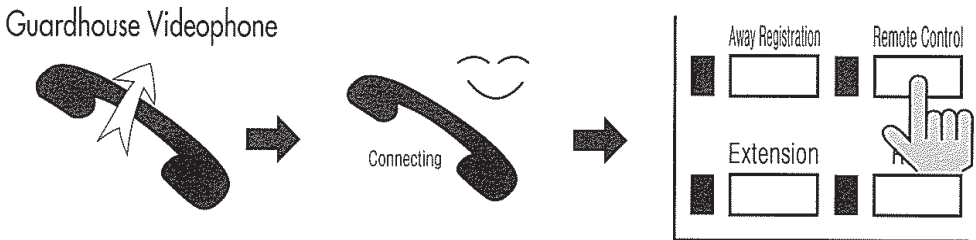

- ③ Enter the Building Number and press the Building button.

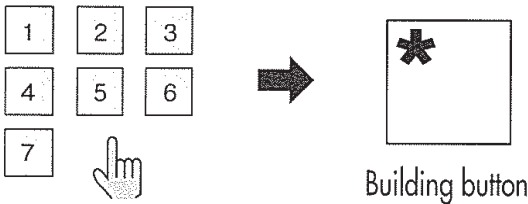

- ④ Enter the Household Number and press the Extension button.

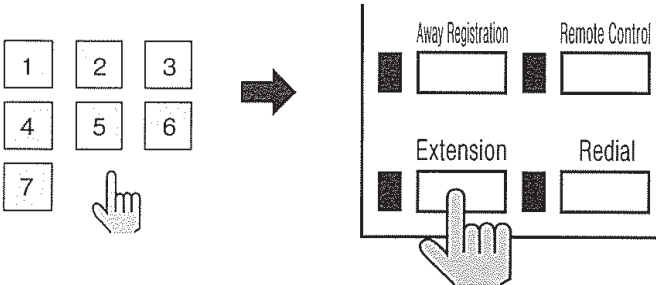

* If the Page button is pressed instead of the Extension button, the Master is registered.

⑤ Enter the Multi Sub Number.

* What is Multi Sub Number?

Refers to individual numbers for each videophone in the Household when there is more than one.

* The Master's Serial Number is 0.

* Sub Serial Numbers are from 1 to 9.

* Maximum 10 videophones can be installed in a household, and their serial numbers must not overlap.

* Register Sub Serial Numbers in the order from 1 to 9.

* A Master must exist among numerous videophones. If only one videophone exists, that unit shall be registered as the Master.

Enter the Multi Sub Number and press the Call button.

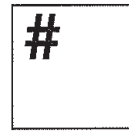
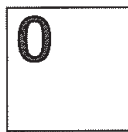

When the Household
is the Master

Call button

16-2. Registering Household Vehicles (Parking Management System)

* Registers two vehicles per Household, and registered vehicle numbers can be used page or reference the Household.

16-2-1. Registering with Known Vehicle Number

① Press the Speakerphone button, then the Remote Control button.

(Just the Remote Control button may be pressed)



② Enter the Building Number and the Household Number, then page.

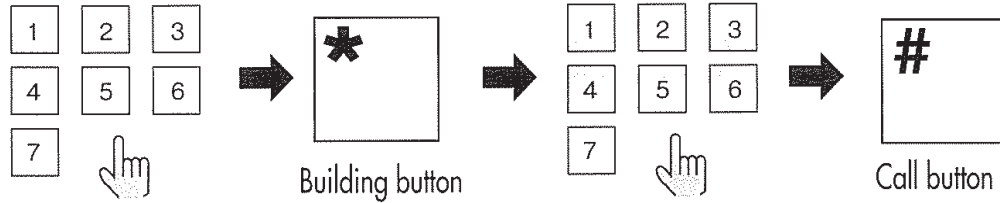

* Already registered data are shown as indicated below:

	Emergency <input type="radio"/>	Away <input type="radio"/>	Call <input type="radio"/>
	Page Number	Household Number	
Guardhouse Indicator	10 1	102	
Household Indicator 1	32	2580	
Household Indicator 2	32	438 1	
Household Indicator 3			
Household			

Household Number

Ex) Unit 102, Building 101

Household Vehicle 1

Ex) Gyeonggi 32Ga2580

Household Vehicle 2

Ex) Gyonggi 32Nuh4381

Not Used

Not Used

③ Press either Household Selection button 1 or 2 for data modification. (Blinking light on the right half of the Household Indicator Section displays whether data can be modified or not)

Household Selection1	Household Selection2	Household Selection3	Household Selection4
<input type="checkbox"/>	<input type="checkbox"/>	<input type="checkbox"/>	<input type="checkbox"/>

④ Enter the vehicle's region and assigned numbers. (*' button distinguishes the two)

Ex) Gyeonggi 32 Ga 2580

⑤ Use the(← , →) buttons to undo wrong entries.

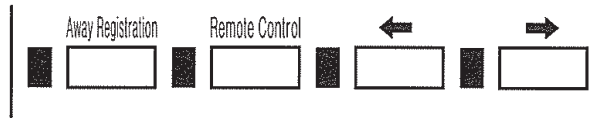

⑥ Press the Remote Control button. (The blinking light stops)

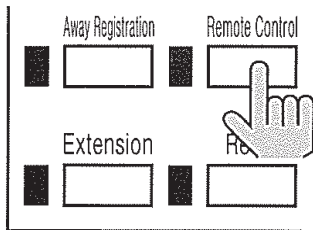

⑦ Press the Call Connect button.

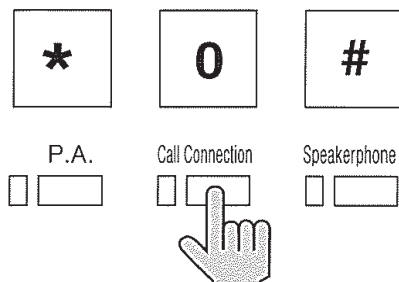

⑧ Press the Speakerphone button to end.

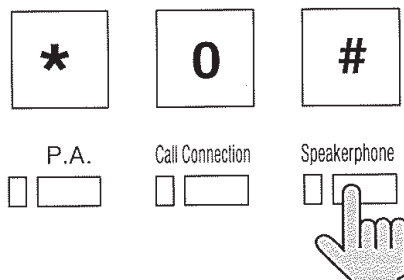

16-2-2. Registration by the Household through the Guardhouse (Only possible when the Household pages the Guardhouse)

① Pickup the receiver and press the Remote Control button while staying connected to the Household.

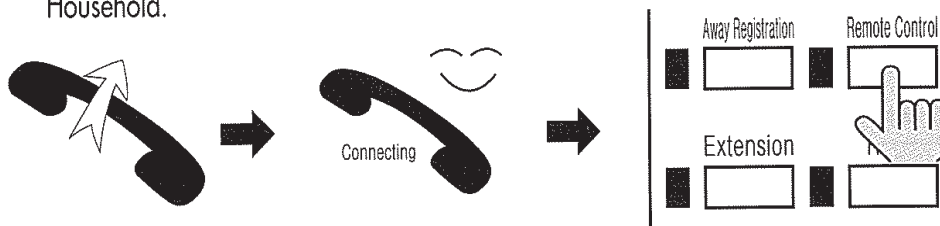

② Registering Household Vehicles (Parking Management System)



Mister, our vehicle number is...
Gyeonggi 32 Ga 2580

③ Enter the vehicle's region number, press the Building button (*), then enter the assigned number.

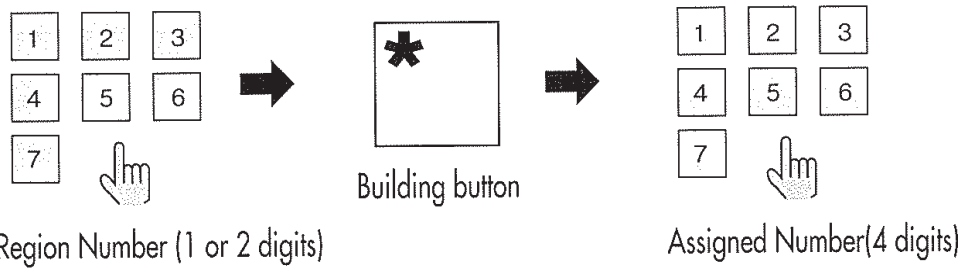
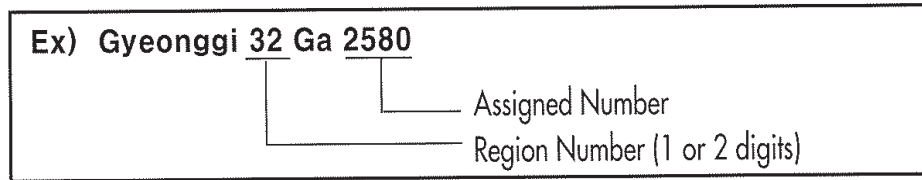

④ Use the (←) button to undo wrong entries.

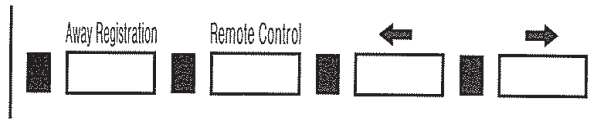

⑤ Select from Entry 1 and Entry 2 for the entered vehicle number to store.

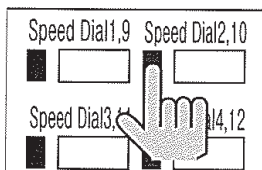

⑥ Put down the receiver to end.



16-3. Checking Household Numbers using Vehicle Numbers

① Press the Speakerphone button.

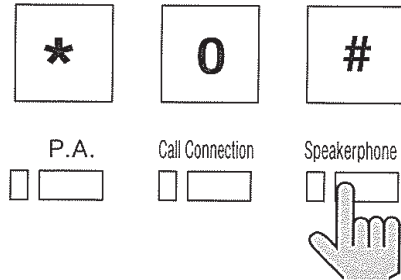

② Press the Confirmation button of the Parking Management System.
("car > - " indicated on the LCD)

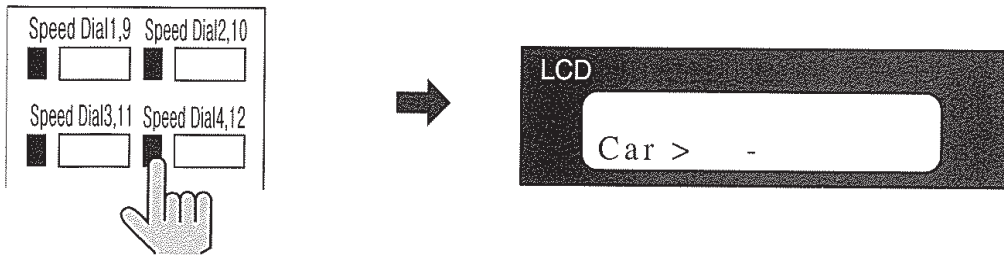

③ Enter the vehicle's region number, then press the Building button. Enter the vehicle's assigned number, then press the Call button.

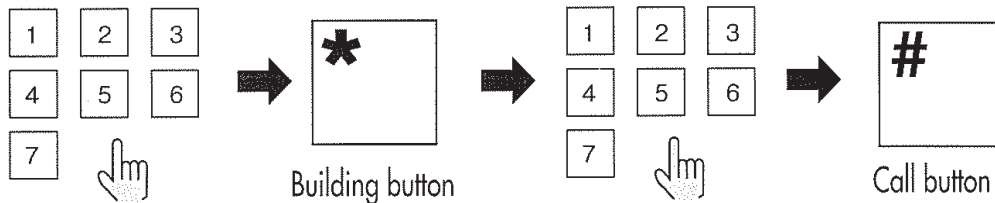

Region Number (1 or 2 digits)

Assigned Number(4 digits)

④ Vehicle number is displayed on the LCD, and the Household Number is displayed on the Guardhouse Indicator Section.



Ex) Vehicle Number of Unit 101, Building 102 being
Gyeonggi 32 Ga 2580

16-4. To Open or Close the Main Entrance

16-4-1. To Temporarily Release the Main Entrance

① Pickup the receiver.



② Enter the Building Number of the Entrance, then press the Building button (*).

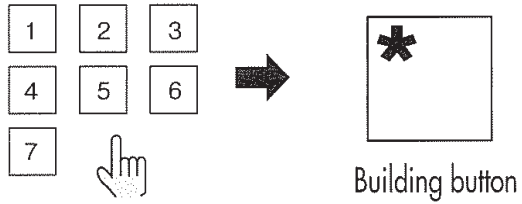

③ Enter the Entrance Interphone's Serial Number, then press the Call button (#).

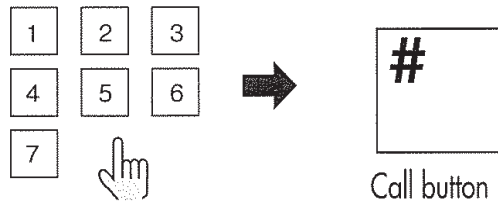

④ Press the Door Release button to open the entrance.

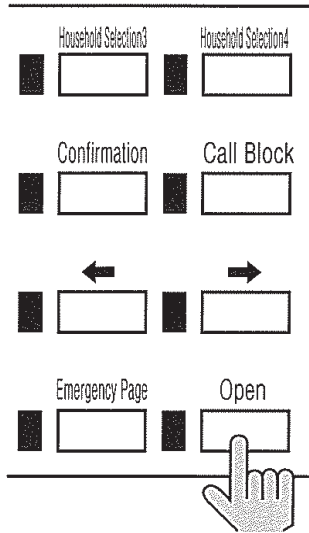

⑤ Put down the receiver to end.



16-4-2. To Open the Entrance for Indefinitely
 (Used to keep the entrance open for moving-in and etc.)

① Press the Speakerphone button.

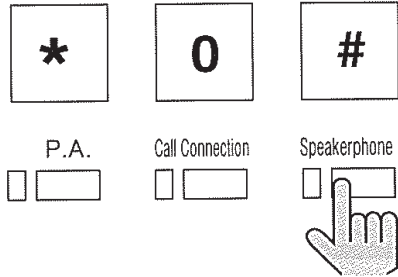

② Enter the Building Number of the entrance, then press the Building button.

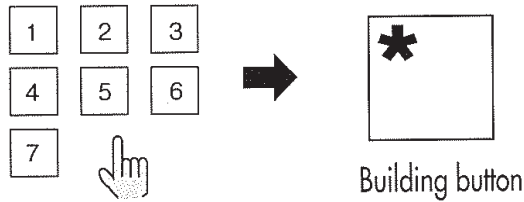

③ Enter the Entrance Interphone's Serial Number, then press the Open button.
 (Entrance opens)

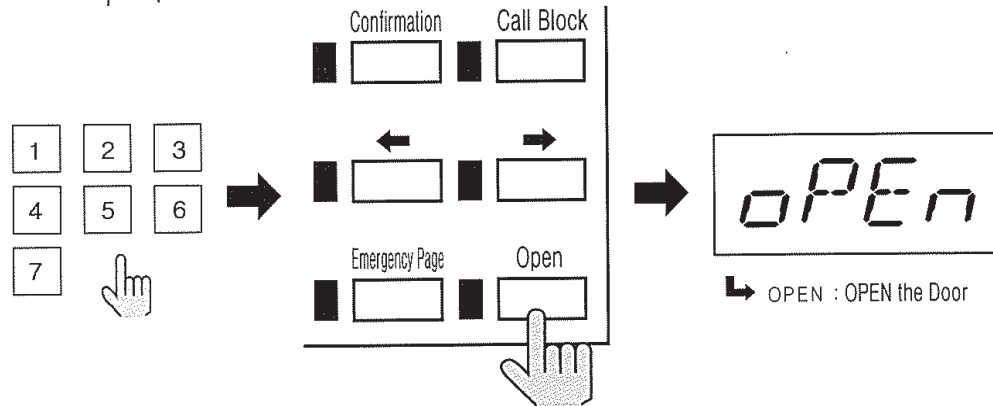

④ The Door Release lamp will stay lit up.
 (When a Main Entrance is opened, the Door Release of all Guardhouse Interphones connected to that entrance remains lit)

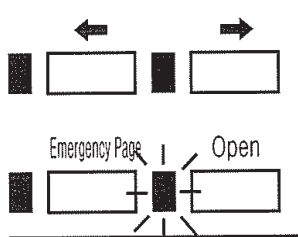

16-4-3. To Close Main Entrances

- ① Press the Door Release button. ("Lobby process" indicated on the LCD)

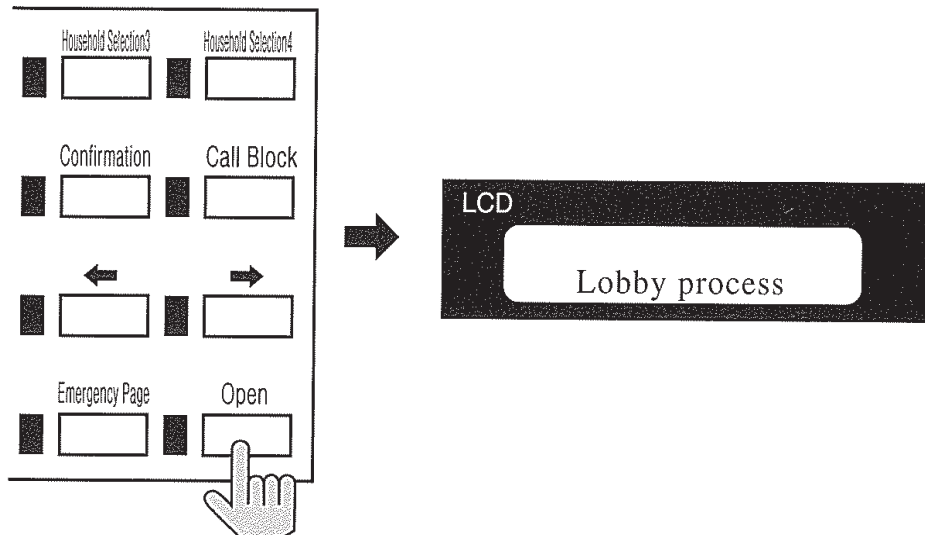

- ② Press the Confirmation button. ("Open Lobby: XX" indicated on the LCD)
 XX is the number of opened entrances.
 (The number of opened entrance interphones is indicated on the Household Indicator Section)

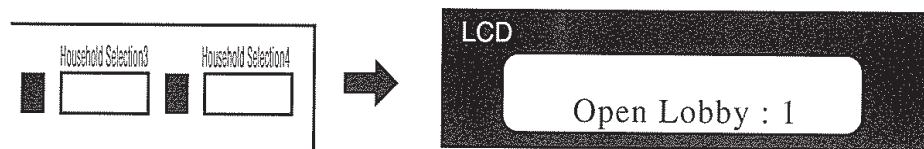

ex) One opened entrance.

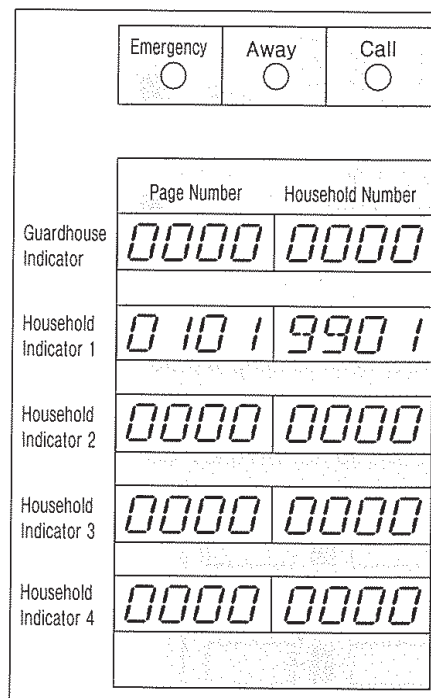

③ With over 5 opened entrances, use (← , →) buttons to scroll through.

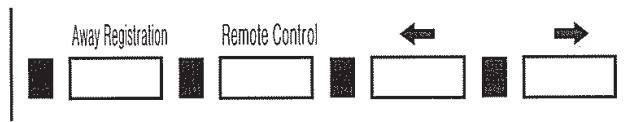

④ Use (← , →) buttons to find the entrance to close and select the entrance interphone using the Household Selection button.

(Selected Entrance Interphone Number moves to the Guardhouse Indicator Section)



Use (← , →) buttons to find the entrance to close



select the entrance interphone using the Household Selection button.

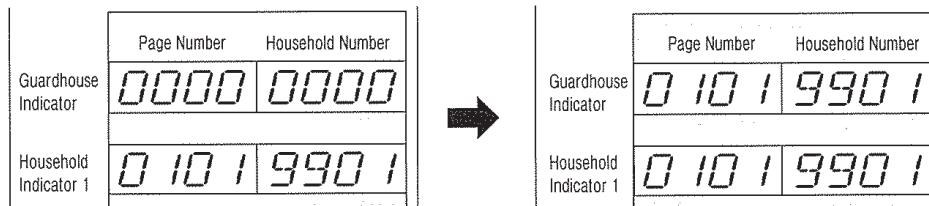

⑤ Press the Open button. (Closes the selected entrance)

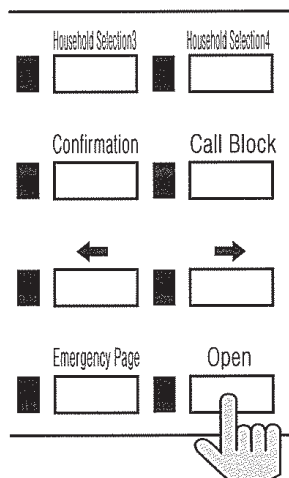

Using Household Select buttons, choose the Main Entrance Interphone.

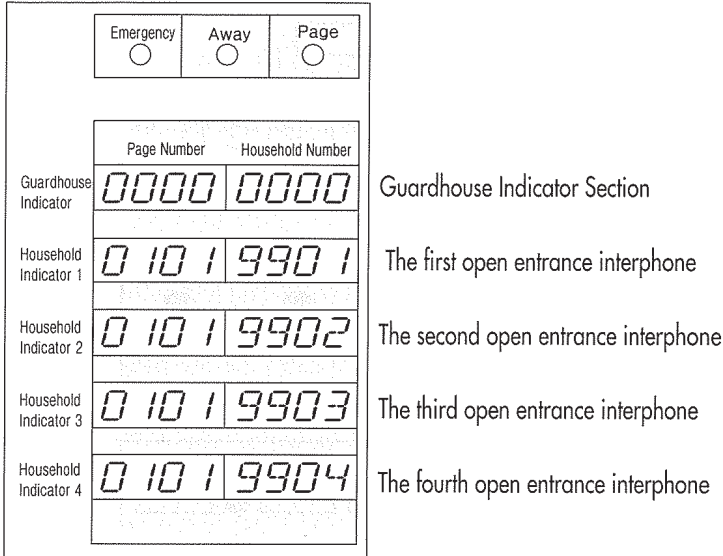

- Guard - : Guardhouse Indicator Section
- Household 1 101 - 9901: The first open entrance interphone
- Household 2 101 - 9902: The second open entrance interphone
- Household 3 101 - 9903: The third open entrance interphone
- Household 4 101 - 9904: The fourth open entrance interphone

* To close the second open entrance (101-9902), press Open and the Confirmation button, press the Household Selection button 2 (101-9902 moves to the Guardhouse Indicator Section), then Open button.

17. Guardhouse Interphone Program Confirmation and Modification

- ① Press the Confirmation button.
(" Password - " indicated on the LCD)

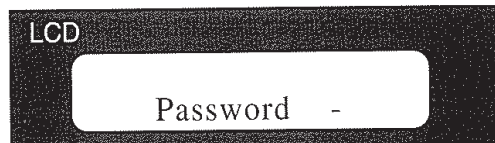
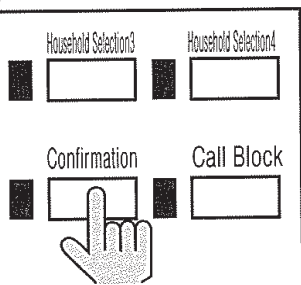

- ② Enter in 9999, then press the Enter button.
(" Program - " indicated on the LCD)

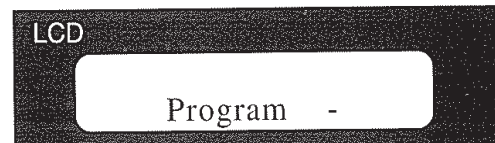
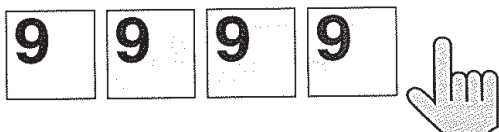

- ③ Use (←, →) buttons to select the desired program.
 (Refer to "Guardhouse Interphone Program Number and Description" of [Table 1])

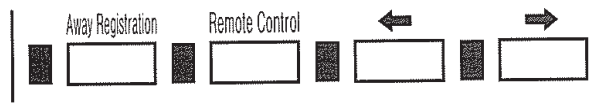

- ④ The following are displayed on the LCD:

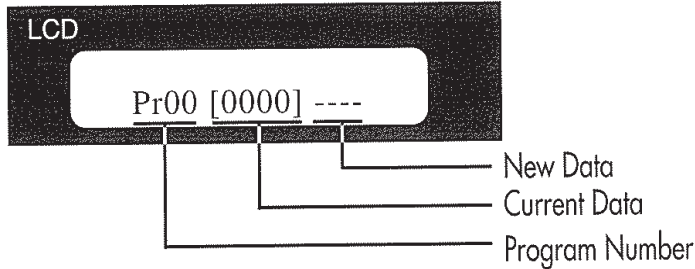

For entry numbers, please refer to "Guardhouse Interphone Program Number and Description" of [Table

- ⑤ Use the Key Pad to enter in the new data, then press the Enter button.

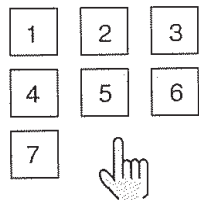

After Entering the Program Number

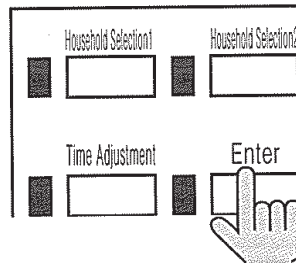

The following steps must be performed to store any modification to the program:
 (Failure to store may result in the modification not being activated)

- ⑥ (←, →) buttons to select Program Number 31.

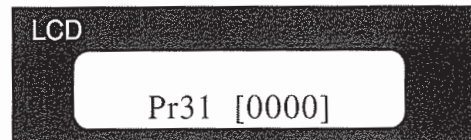
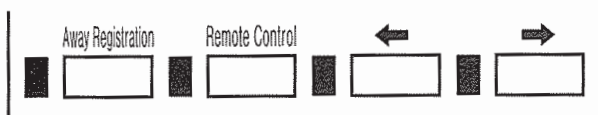

- ⑦ Use the Key Pad to enter in 8888, then press the Enter button

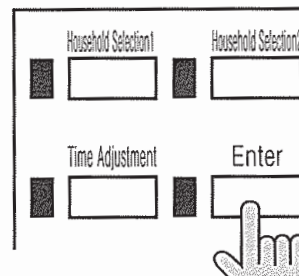
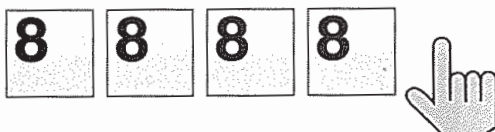

- ⑧ Entry lamp will turn on, and "Prog[XXXX]Wait" will display on the LCD.
 (Do not power off until the Entry lamp turns off. The entries may be erased)

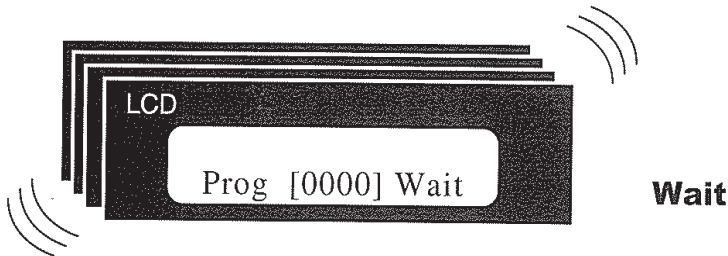

- ⑨ Press the Speakerphone button to end.

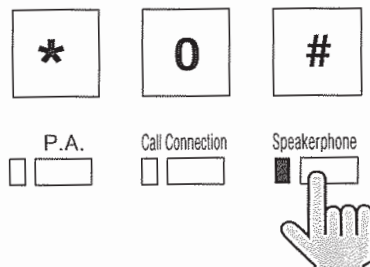

Do not modify Programs 00 and 01, except for during installation.
 Improper modifications will disable the calling feature.

ex) Example of Guardhouse Interphone Program Confirmation and Modification

- ♣ Enter when the Sub building the Guardhouse Interphone is in charge of are Buildings 101 and 102

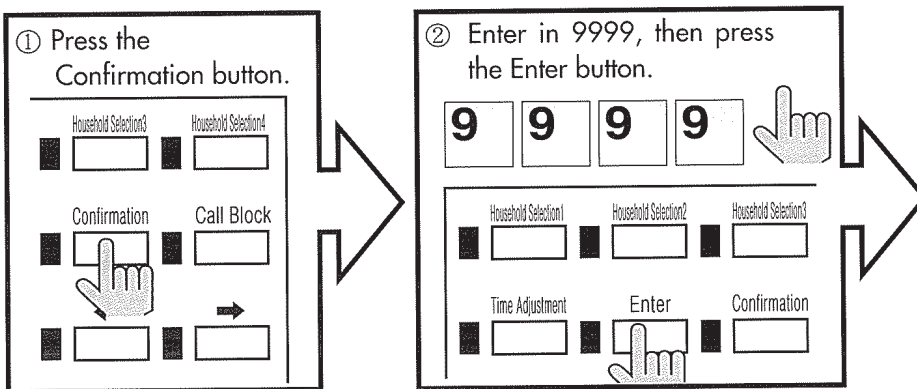

③ Use (←, →) buttons to select "Pr 05".

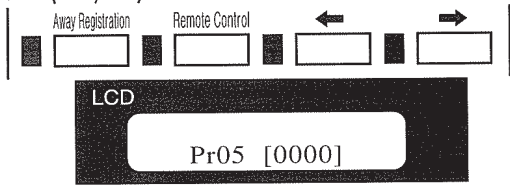

LCD
Pr05 [0000]

④ Enter in "101"(Building No.), then press the Enter button.

"After Entering 101"

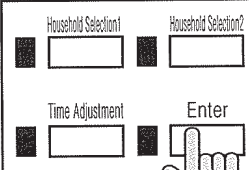

⑤ Use (←, →) buttons to select "Pr 06".

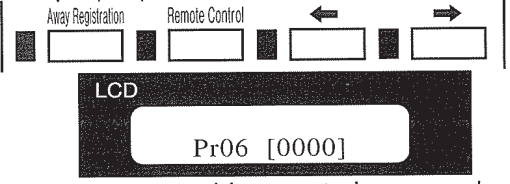

LCD
Pr06 [0000]

⑥ Enter in "102"(Building No.), then press the Enter button.

After Entering 102

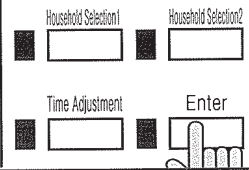

- ⑨ Do not power down until the entry lamp has turned off. From now, Buildings 101 and 102 must not be overlapped as the SUB buildings of any other Guardhouse interphones.
Important!

Floor distributor information change method

- * This function only works when floor distributor is installed.
- * Public entrance lobby phone will not work while performing this function.

- 1) Execute internal Program '24" in guard station interphone
- 2) After entering 9700-XXXX(8 digits floor distributor ID), press input button
- 3) Please wait until floor distributor information download is completed.
- 4) After download is completed, display will show as below. Then, select household (Port No.) which information change is required by using (←, →) buttons.

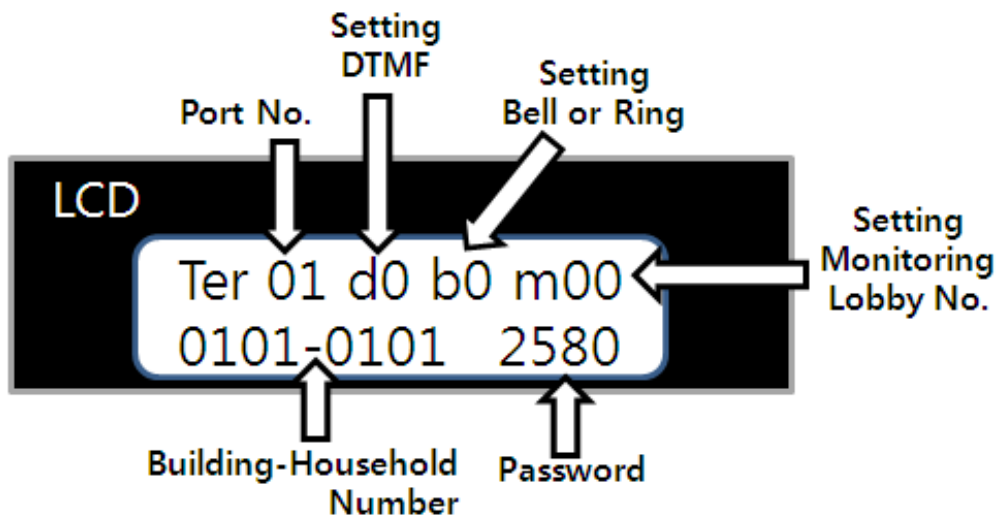

- 5) On selection of household, press input button
- 6) Select the category and change the information.
 - Among category
 - 1) Video Floor distributor : Only display monitoring lobby No.
 - 2) Audio Floor distributor : Only display usage of DTMF
 - 3) Video/Audio Integrated floor distributor : Display all categories above.
 - DTMF(0:Disable, 1:Enable), Bell or Ring(0:Bell, 1:Ring)
- 7) When all change is made, press remote control button.
- 8) Change information is uploaded to floor distributor.

[Table 1] Guardhouse Interphone Program Number and Description

Program Number	Description	Selection
Pr 00	Device Number: The Guardhouse Interphone's Serial Number	Enter from 0001 to 9000
Pr 01	Set "Call"(See below detail explanation) 0000(Basic): Internal 3 lines/ Budling to building 8 lines 0101~0308: Call Lines Change	Basic : 00(Internal)00 (Building to Building) Internal : Line1~Line 3(01~03) Building to Building : Line1~Line8(01~08)
Pr 02	Call Times -0000: Calls automatically terminated after 3 minutes. -0001-0007: Extensions	0000 : 3 minutes
Pr 03	Building Number and Household Number to forward calls toduring Call Block.	Building No. + Unit No.
Pr 04	Call Block Config.	0000: Disable, 8888: Enable
Pr 05	No. 1 Sub Building No. Assigned to the Guardhouse Interphone	1st Building No.
Pr 06	No. 2 Sub Building No. Assigned to the Guardhouse Interphone	2st Building No.
Pr 07	No. 3 Sub Building No. Assigned to the Guardhouse Interphone	3st Building No.
Pr 08	No. 4 Sub Building No. Assigned to the Guardhouse Interphone	4st Building No.
Pr 09	No. 5 Sub Building No. Assigned to the Guardhouse Interphone	5st Building No.
Pr 10	No. 6 Sub Building No. Assigned to the Guardhouse Interphone	6st Building No.
Pr 11	No. 7 Sub Building No. Assigned to the Guardhouse Interphone	7st Building No.
Pr 12	No. 8 Sub Building No. Assigned to the Guardhouse Interphone	8st Building No.
Pr 13	No. 9 Sub Building No. Assigned to the Guardhouse Interphone	9st Building No.
Pr 14	No. 10 Sub Building No. Assigned to the Guardhouse Interphone	10st Building No.
Pr 15	No. 11 Sub Building No. Assigned to the Guardhouse Interphone	11st Building No.
Pr 16	No. 12 Sub Building No. Assigned to the Guardhouse Interphone	12st Building No.
Pr 17	No. 13 Sub Building No. Assigned to the Guardhouse Interphone	13st Building No.
Pr 18	No. 14 Sub Building No. Assigned to the Guardhouse Interphone	14st Building No.
Pr 19	No. 15 Sub Building No. Assigned to the Guardhouse Interphone	15st Building No.
Pr 20	No. 16 Sub Building No. Assigned to the Guardhouse Interphone	16st Building No.
Pr 21	Ringing tone of the Guardhouse Interphone 0000=Bell 0001=Melody	0000=bell 0001=melody

Program Number	Description	Selection
Pr 22	Announcement Groups	01-99: Group Number
Pr 23	Speed Dial 1	Building No. + Household No.
Pr 24	Floor Distributor Setting Change	Floor Distributor ID input
Pr 25	Household interaction method selection	0000 : 481 0001 : 480
Pr 26	VD-1602 usage setting	0000 : Not in use 0001 : Use
Pr 27	Communication Speed Modulation	Basic : 1200 Option : 2400
Pr 28	Control by Line	0000 : Not in use 0001 : Use
Pr 29	Line No. Setting Ex) 0104 : Line 1-Line 4 Setting	0000 : Not in use
Pr 30	Master Setting Guard station master setting is required on SECUMAX connection. At least 1 master must be installed on Multiple installation.	0001 : Master 0000 : Basic
Pr 31	Data Storage Requirements	8888

<Note>

Pr 01: Internal & building to building setting is possible and consists of 4 digits(0000).

Basic setting is set 0000(Internal 3 lines /Building to building 8 lines and internal/building to building can be set separately.

Front 2 digits (Maximum 3 Lines, Line 01~ Line 03) can be set for Internal setting.

Back 2 digits (Maximum 8 Lines, Line 01~Line 08) can be set for building to building setting.

However, all commonly connected guard station setting must be the same.

Pr 02: Call time is set by default as 3 minutes. Values 0001 to 0007 are additional minutes to the standard 3 minutes.

(Values other than 0001 to 0007 are not accepted)

※ Modified data is stored in all installed Guardhouse and Household Interphones.

Pr 03: Connection is only available when calls are set to forward to Household Interphones.

Various added features do not function.

Pr 05 to Pr 20: If a Building No. is not designated as the Building Number assigned to the Guardhouse Interphone, pages from the Guardhouse to Households will not go through.

Pr 31: Always store after making modifications. Failure to store may result in the modification not being activated

18. Wiring Method

1) Guardhouse Interphone (CDS-481L)

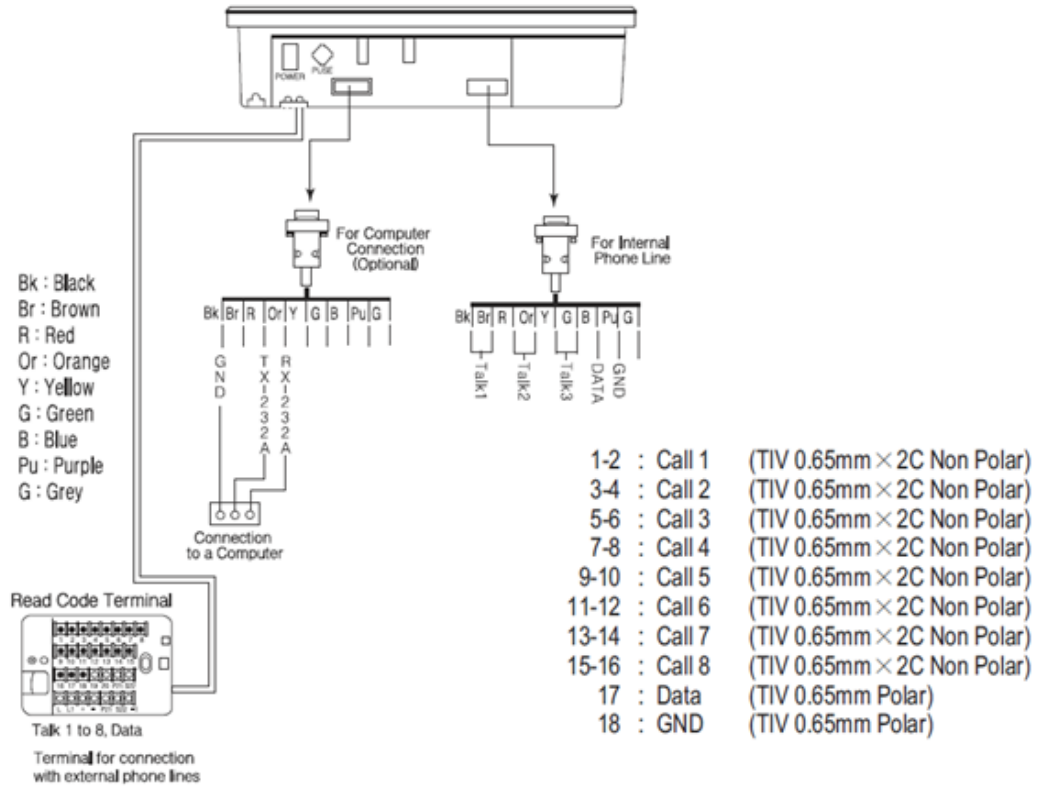

2) Main Entrance Interphone (DRC-481L)

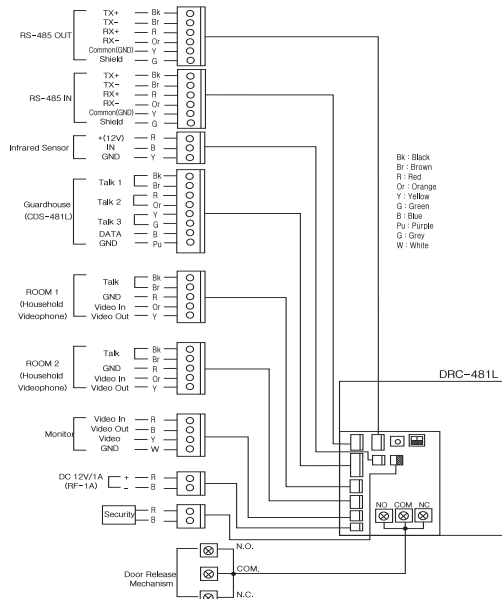

*Security

- ① DC 12V used.
- ② Designed to be used by connecting to the lead switch. When not in use, please connect two wires.
- ③ When the Main Entrance is opened by force, the Guardhouse and the computer are notified.

3) Household Videophone (CH-481SL)

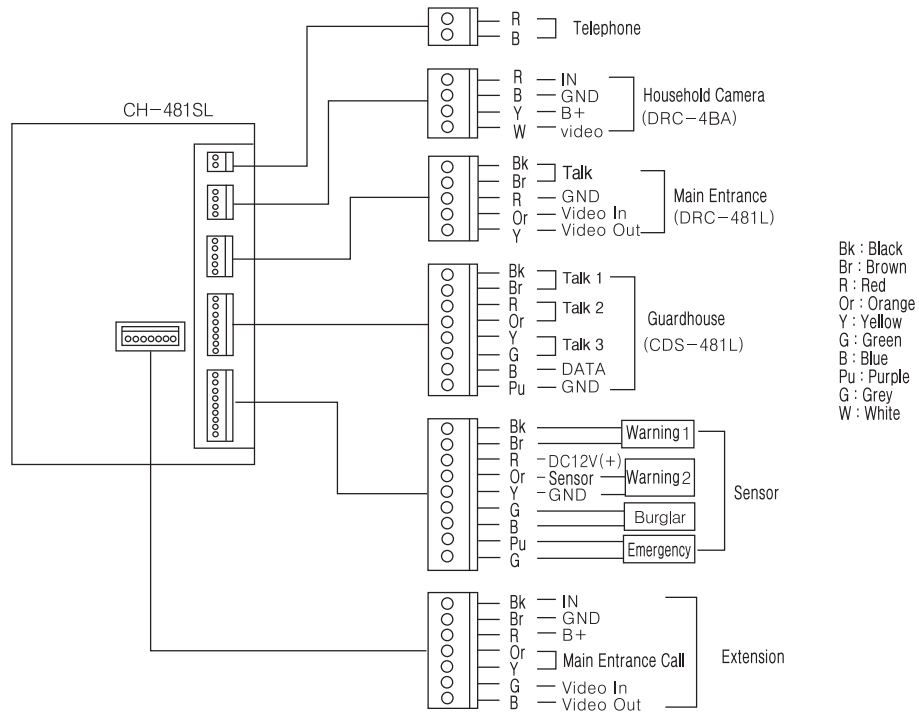

4) Household Videophone (APV-481FT)

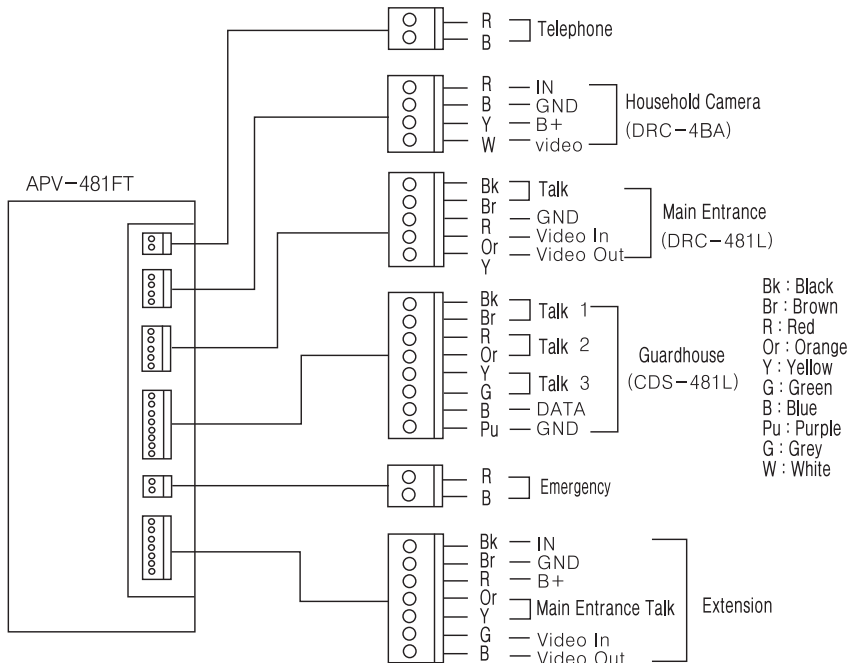

5) Household Videophone (CAV-60FSD)

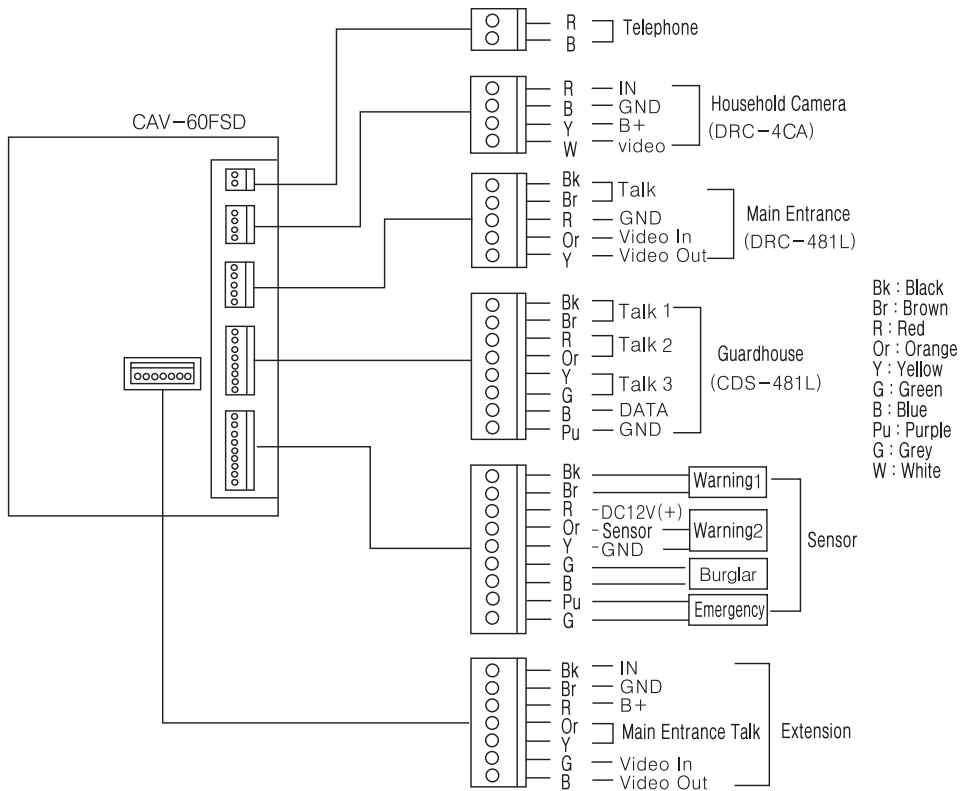

6) Household Videophone (CAV-60FD)

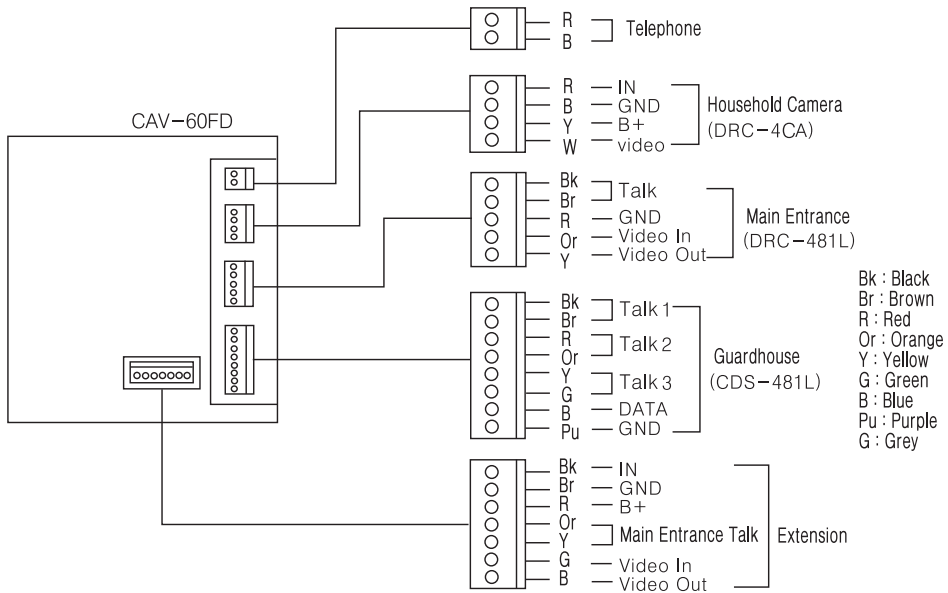

7) Household Videophone (CAV-561D)

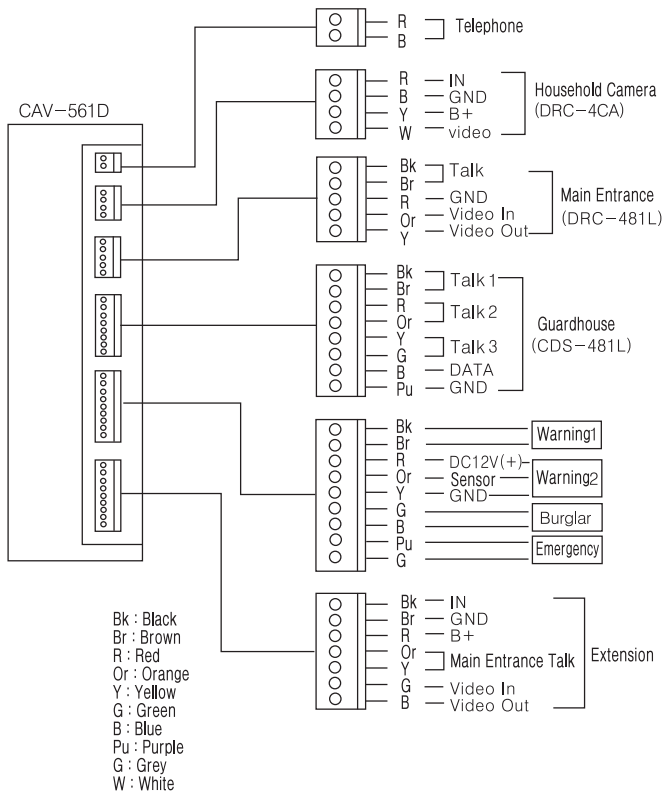

8) Household Videophone (CAV-482S)

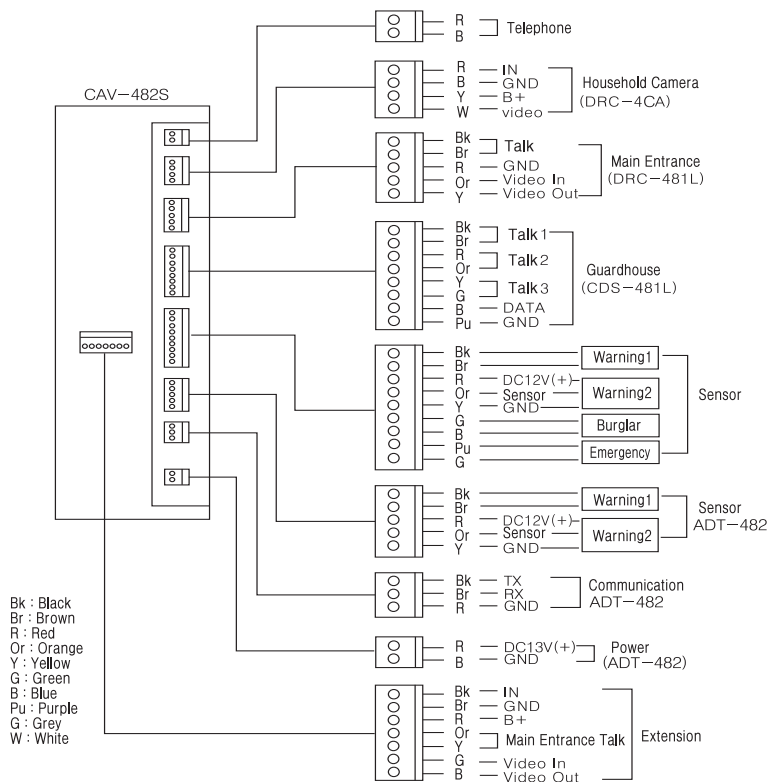

9) TV-Phone Interface Adaptor(ADT-481)

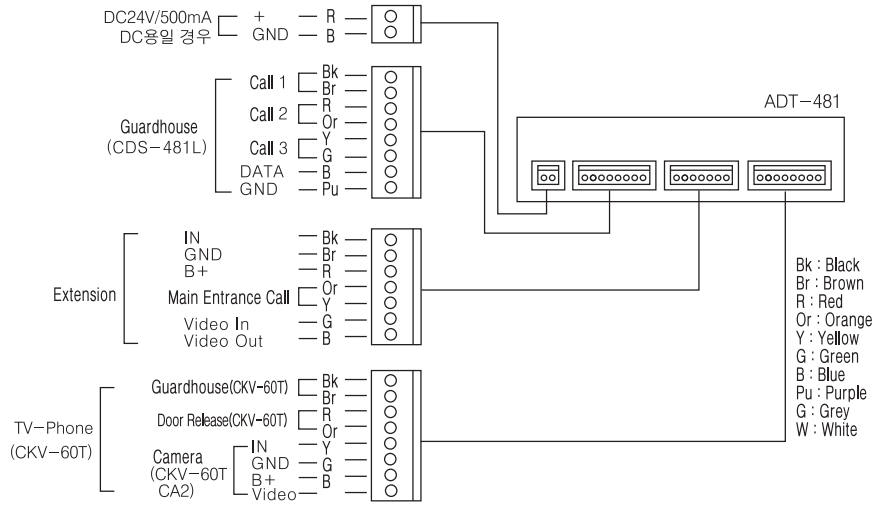

10) Security Interface Adaptor(ADT-482)

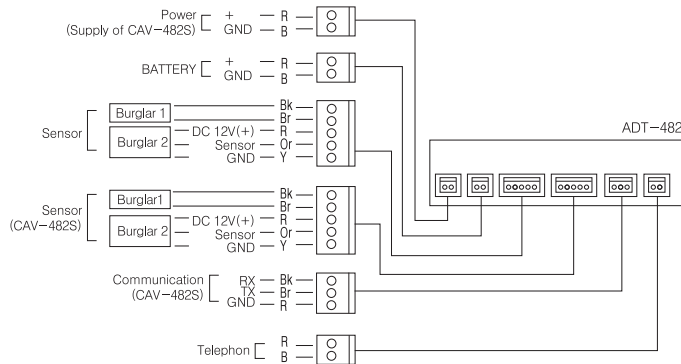

11) System Map

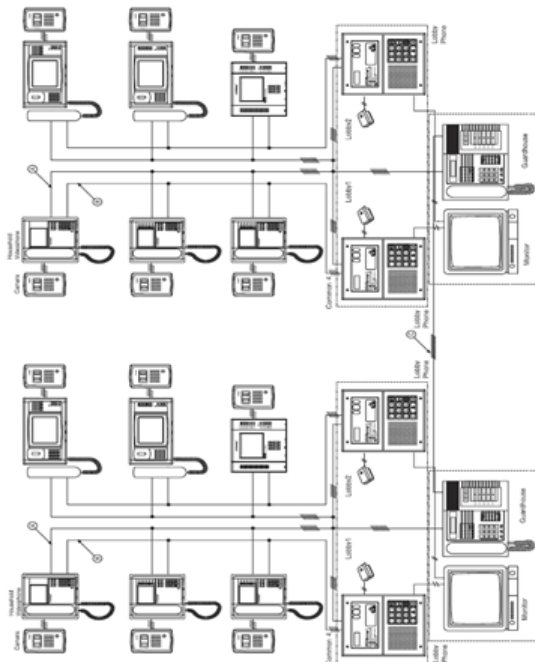

※ Note
A: Guardhouse Line (Common 8-wire)
B: Main Entrance Line (Common 4-wire)
C: External Call Line (Common 18-wire)

12) Wiring Method for Communications with the Guardhouse

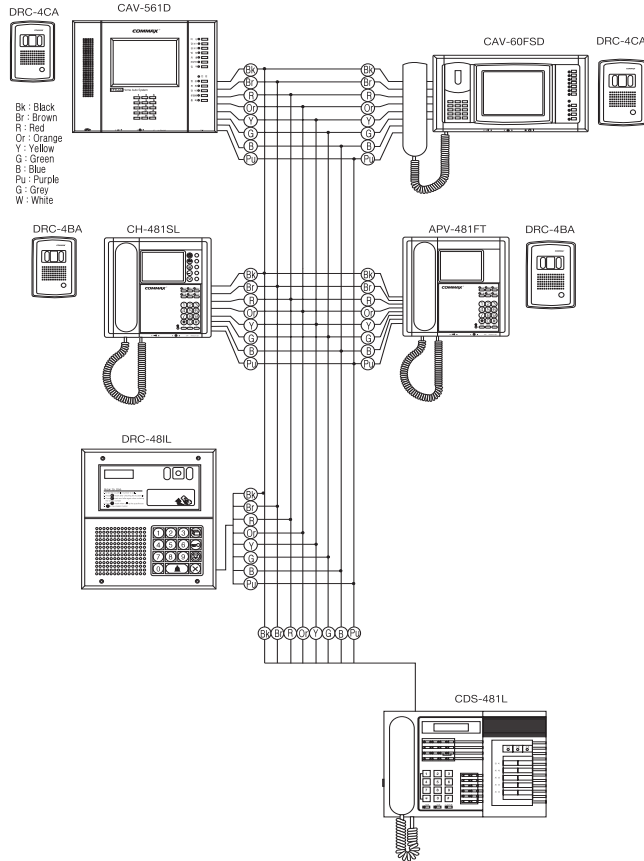

13) Main Entrance Interphone Wiring

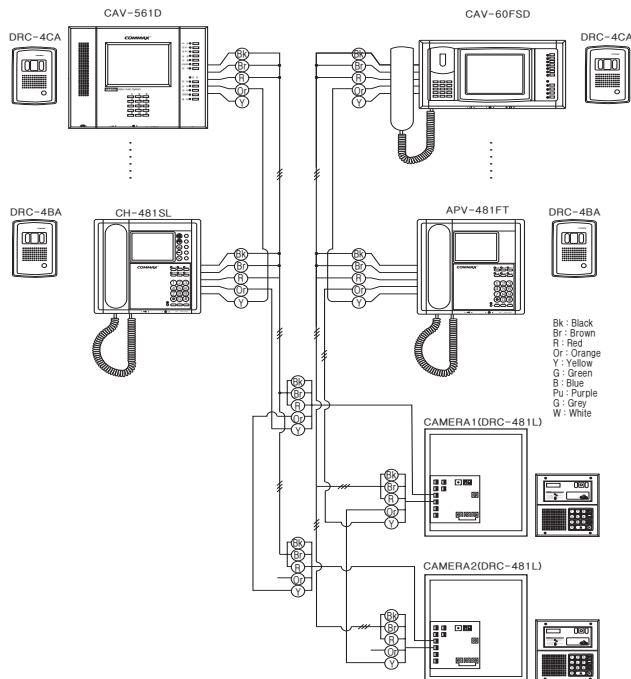

※ NOTE

1. Main Entrance System

- Bk ————
- Br ———— CALL
- R ———— GND
- Or ———— VD/IN
- Y ———— VD/OUT

2. Household Videophone

- Bk ————
- Br ———— CALL
- R ———— GND
- Or ———— VD/IN
- Y ———— VD/OUT

- 3.If the Guardhouse Interphone (CDS-481L) has been installed, Number 7 (Data) and 8 (GND) connected to it must be connected to the Household Interphone.
- 4.Use coaxial cables (3C2V or 5C2V) for Video Out.

14) Wiring ADT-481 and CKV-60T

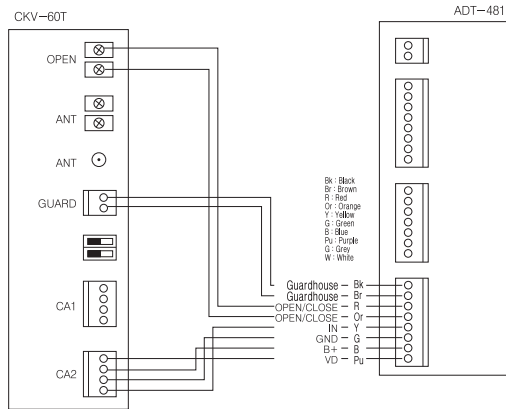

15) Wiring ADT-482 and CAV-482S

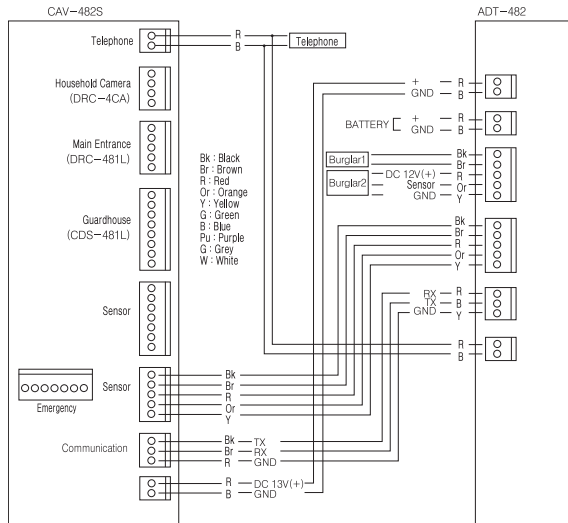

16) Installing Numerous Videophones in a Household

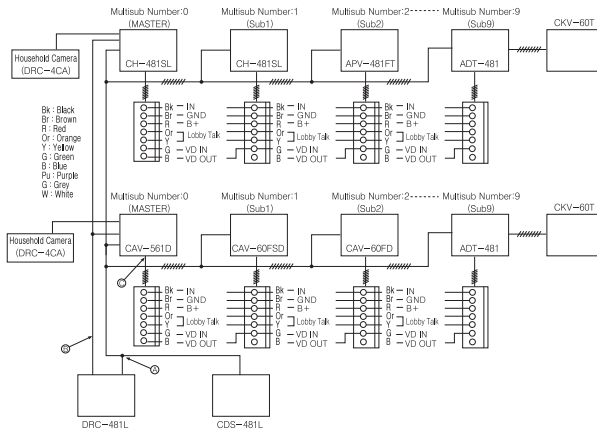

※ Note

1. A: Guardhouse Line (8-wire Common)
B: Main Entrance Line (4-wire Common)
C: Sub Extension (6-wire Common)
2. When registering the Multi Sub number, ADT-481 will not be recognized as the Master and should be installed last as shown above.
3. Various types of sensors should be connected to the Master, and sensors of the remaining Subs should be connected with the + wire and the sensor line: if the two lines are not connected, the Away mode will not function.

17) CCTV and Sensor Wiring

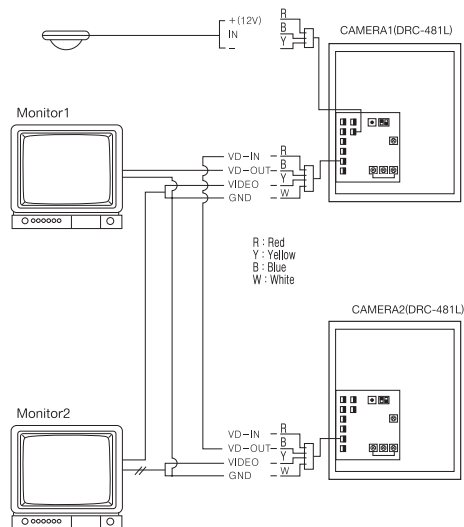

※ NOTE

1. Monitor 1: To view only when being used by the Main Entrance Interphone (DRC-481L).
2. Monitor 2: Continuous surveillance of the Main Entrance.

18) Wiring DRC-481L and CDS-481PC

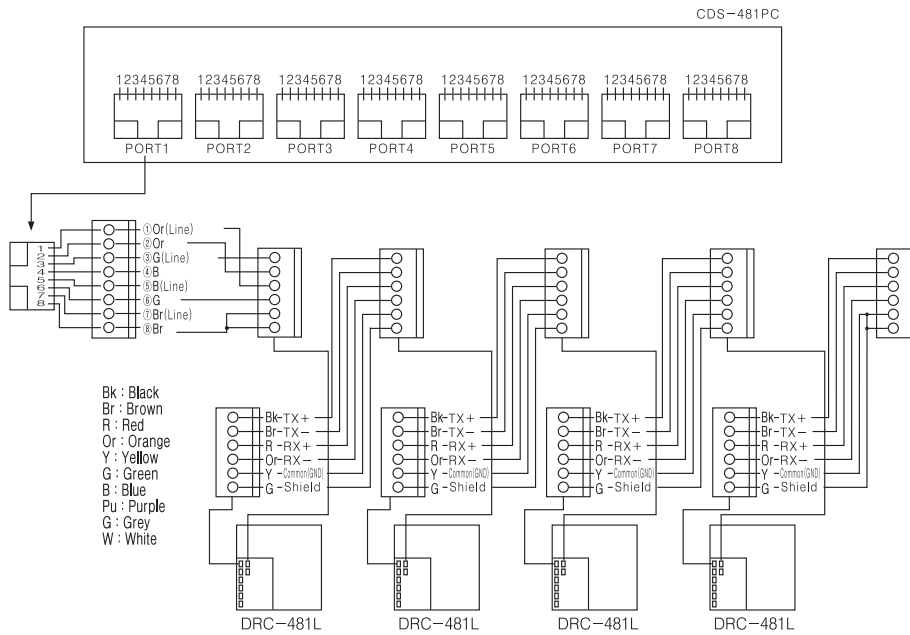

※ NOTE

To be wired when the Finger Print Recognition device has been installed, and the wiring must use STP 4P.

19) Wiring CDS-481PC and Multi Port

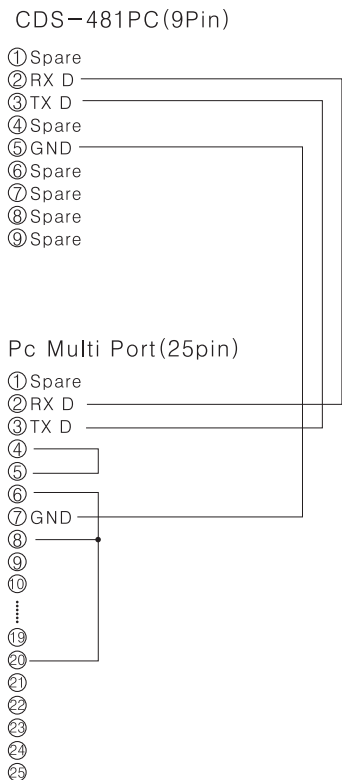

19. Specifications

Specification \ Model	CDS-481L
Transmission System	Household Interphone (8-wire common), Outside Line: 8-wire common,
Rated Voltage	AC 110 ~ 220V (60Hz) (FREE VOLTAGE)
Power Consumption	Max: 10W, Standby: 4.5W
Communication Method	Synchronous Communication Method
Communication Distance	1Km Using ϕ 0.65mm Cable
Ambient Temperature	-10°C ~ +50°C
Dimensions	328(W) × 230(H) × 97(D)mm

COMMAX

COMMAX Co.,Ltd.

513-11, Sangdaewon-dong, Jungwon-gu, Seongnam-si, Gyeonggi-do, Korea

Int'l Business Dept. Tel. : +82-31-7393-540~550 Fax. : +82-31-745-2133

Web site : www.commax.com

PM04481L0010

Printed In Korea / 2014.04.104