

TAMRON Machine Vision Lens (f=6.5mm)

P/N		22HA
CCD size		2/3"
Mount		C mount
Focal length		6.5mm
Aperture range		1.8 - Close
Angle of View (horizontal x vertical)	2/3"	71.6 x 55.5
	1/2"	53.9 x 41.0
	1/3"	41.0 x 31.0
Focusing range		1.5m-infinity
Operation	Focus	-----
	Iris	Manual w/lock
Filter size		M35.5 P=0.5mm
Back focus (in air)		13.00mm
Exit Pupil Position		-31.8mm
1 st Optical Principal Point		17.986mm
2 nd Optical Principal Point		6.397mm
Distance between 1 st & 2 nd		23.811mm
Effective Diameter	Front	24.8mm
	Rear	10.8mm
Optical Construction		6 groups / 7 elements
Distortion		-2.16%
Optical Overall Length		35.40mm
Maximum Diameter		37mm
Weight		60g
Operating Temperature		-5 + 50C

For High Quality Machine Vision

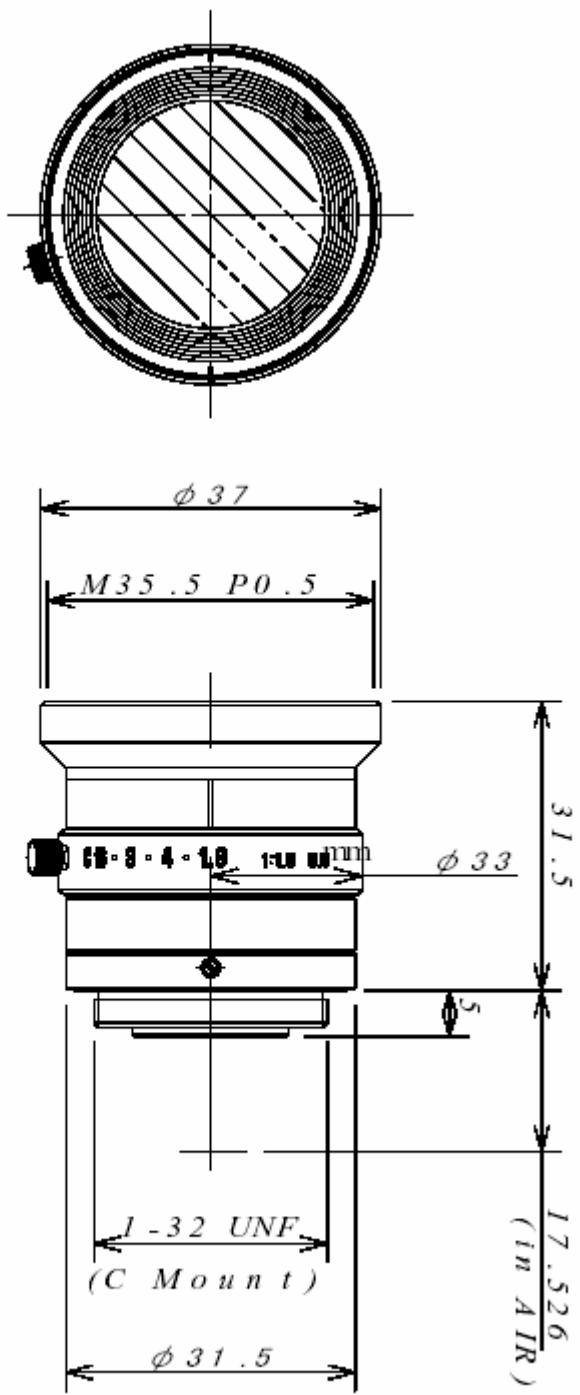

23FM65
 2/3 6.5mm F/1.8 MANUAL Iris